

Photovoltaic Systems Use Reed Relays to Monitor Isolation Control



Products for tomorrow...

REED RELAYS ■ REED SENSORS ■ REED SWITCHES

A photovoltaic system has to have excellent isolation. Without proper isolation, currents will flow off into the ground, which will not only cause a loss of power, but may also be very dangerous. Isolation resistance is made up of different components:

- PV Module
- DC Cable
- Inverter

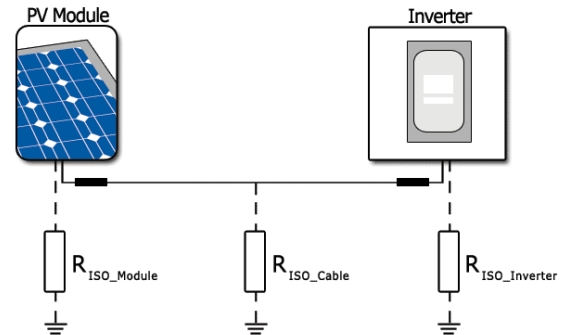

Inverters without internal transformers are not electrically isolated from the power net.

According to DIN VDE 0126-1-1, however, the isolation must not drop below a certain minimum.

Because of the missing galvanic isolation, it is not possible to measure the isolation resistance while the system is in operation. Therefore the isolation resistance is measured before the inverter is connected to the power net (current sensitive fault protection).

Modern inverters have an integrated isolation control which monitors all components for potential failures. This control system poses high requirements for the Relay.

Reed Relays designed by MEDER meet those requirements perfectly. Despite its small size, the Relay has an isolation resistance of up to >10G Ohm. Another advantage is the low power consumption. Reed Relays only need energy during the switching process which has a positive influence on the overall efficiency of the inverter. Because of the high number of switching cycles (>10⁹), the Reed Relay is suitable for long life applications.

Reed Relay Products

Operating Characteristics / Dimensions									
Relay Series	Coil Voltage	Breakdown Voltage	Switching Voltage	Isolation Resistance	Switching Current	Carry Current	Power	Contact Form	Dimension L x W x H
	V(DC)	Max (VDC)	Max (VDC)	Max (Ω)	Max (A)	Max (A)	Max (W)	Normally Open	(mm)
LI	5,12,24	5,000	1,000	>10T	1,0	2,5	100	1-Form A	30 x 10 x 10.4
BE	5,12,24	2,000	1,000	>1T	1,0	2,5	100	1-Form A	33 x 10 x 10.0
KT	5,12,24	5,000	1,000	>10T	1,0	2,5	100	1-Form A	30 x 11 x 9

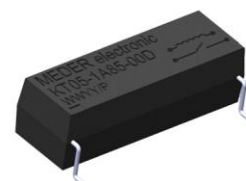

Application