

# Magnecraft™ Time Delay and Sensor Relays

Catalog  
2012

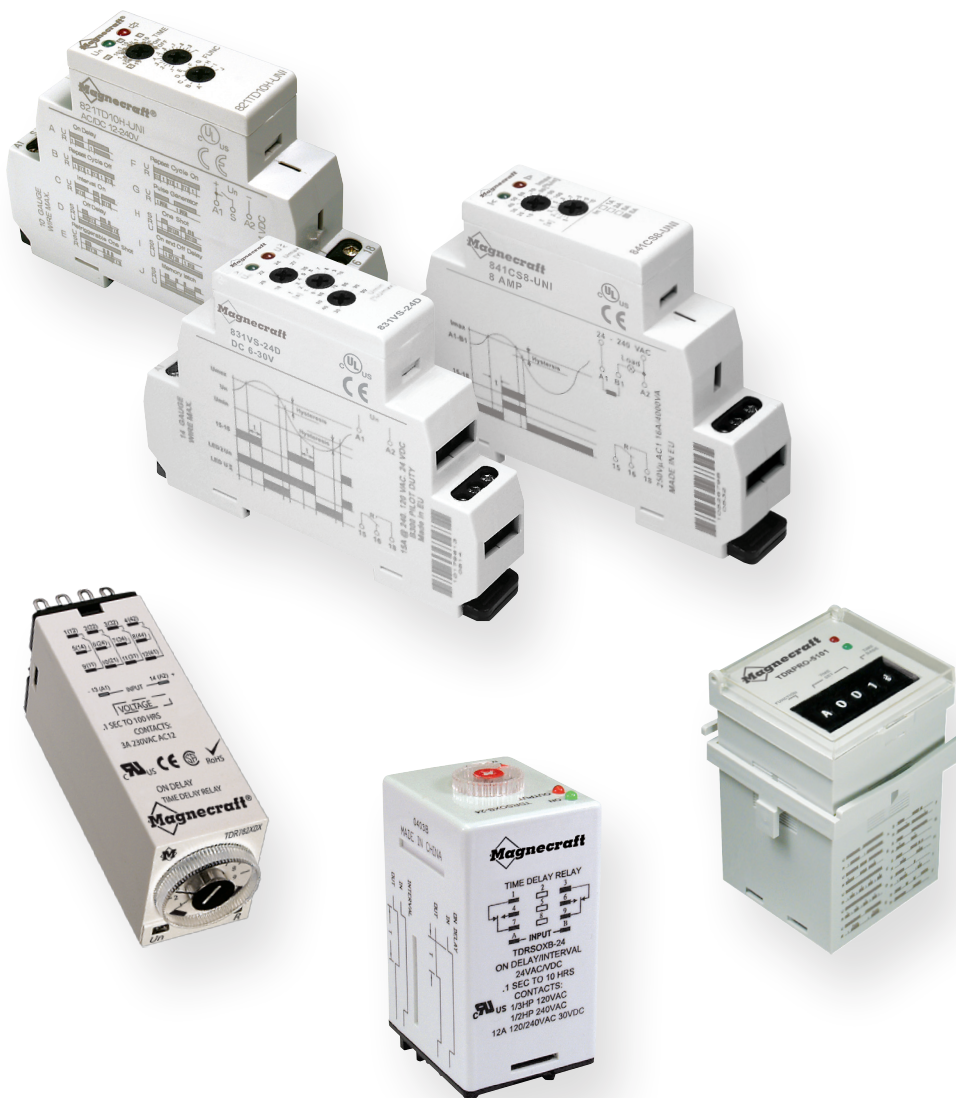

**Schneider**  
Electric™

# Magnecraft™ Time Delay and Sensor Relays

---







■ Series Overview . . . . .	3
■ 820 Series Relays . . . . .	4
■ 831 Series Voltage Sensing Relays . . . . .	7
■ 841 Series Current Sensing Relays . . . . .	10
■ 800 Series Accessories . . . . .	13
■ TDR782 Series Relays . . . . .	14
■ TDR782 Series Accessories . . . . .	17
■ TDRPRO Series Relays . . . . .	22
■ TDRSOX/SRX Series Relays . . . . .	25
■ TDRPRO/SOX/SRX Series Accessories . . . . .	28
■ Application Data . . . . .	33
■ Website Guide . . . . .	37
■ Index . . . . .	38

# Magnecraft™ Time Delay and Sensor Relays

Magnecraft time delay and sensor relays are designed to provide cost effective solutions for your industrial timing and sensing needs. Available in a wide array of forms, fits and functions, Magnecraft timers offer the ultimate in flexibility and performance. Accurate adjustments, legible wiring diagrams and an interactive timer demo make selection quick and easy.

## Key Features

- Multiple timing functions
- Wide voltage range from 12 to 240 V
- Single timing range or from 100 ms to 10 days
- DIN or Panel mounting styles
- Conforms to international standards including UL, CSA, RoHS and CE IEC

Series	Style	Contact Configuration	Rated Current Load (A)	Timing Range	Number of Functions	Function Type	Input Voltage Range	Page
 <b>820 Relays</b>	Time delay relay DIN mount	SPST	15	100 ms to 10 days	10	All	12 to 240 Vac/Vdc	4
		DPDT						
 <b>831 Voltage Sensing Relays</b>	Voltage Sensing DIN mount relay	SPDT	15	100 ms to 10 sec	1	On Delay	120 Vac; 240 Vac; 24 Vdc	7
 <b>841 Current Sensing Relays</b>	Current sensing DIN mount relay	SPDT	15	100 ms to 10 sec	1	On Delay	24 to 240 Vac	10
 <b>TDR782 Relays</b>	Time delay relay Plug-in w/ Dial	DPDT	5	100 ms to 100 hrs	1	On Delay	12, 24 Vdc; 24, 110, 230 Vac	14
		4PDT	3					
 <b>TDRPRO Relays</b>	Time delay relay Plug-in w/ 5 Digit Thumbwheel	SPDT	12	100 ms to 9990 hrs	10	All	12 to 240 Vac/Vdc	22
		DPDT			3	On Delay / Repeat Cycle / On Interval		
 <b>TDRSOX Relays</b>	Time delay relay Plug-in w/ Dial & DIP switches	DPDT	12	100 ms to 10 hrs	2	On Delay Interval	12 to 120 Vac/Vdc; 240 Vac	25
 <b>TDRSRX Relays</b>	Time delay relay Plug-in w/ Dial & DIP switches	DPDT	12	100 ms to 10 hrs	2	Off Delay Retriggerable one shot	12 to 120 Vac/Vdc; 240 Vac	25

## Description

# Magnecraft™ Time Delay and Sensor Relays

## 820 Series

### SPDT, 15 A; DPDT, 15 A

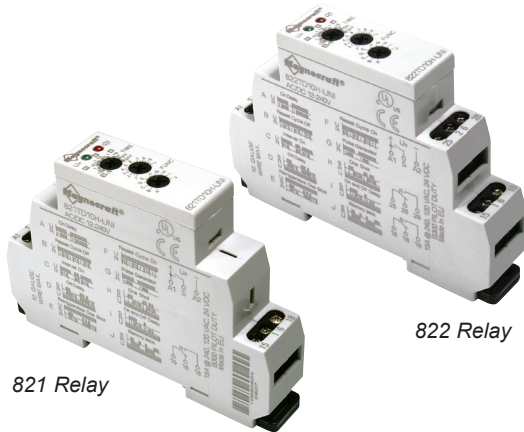

## Description

The 820 Series Time Delay Relays are 35 mm DIN rail mountable products offering 10 different timing functions, ultra-wide timing range (10 ms to 10 days) and a universal voltage input (12-240 Vac/Vdc), all in a slim 17.5 mm (0.69 in) modular package.

Feature	Benefit
Up to 10 functions	5 timing functions controlled via supply voltage 4 timing functions controlled via trigger input 1 function of memory latching Meets most timing requirements
Contact configuration	SPDT or DPDT
Universal power supply	12 to 240 Vac/Vdc
2 LED status indicators	Shows status at a glance
Only 17.5 mm (0.69 in) wide	Ideal for tight spaces
DIN rail mountable	Easy installation / Screwdriver required
RoHS compliant	Environmentally friendly

Input Voltage	Functions Available (1)	Timing Range	Contact Configuration	Rated Current (A)	Standard Part Number
12-240 Vac/Vdc	A,B,C,D,E,F,G,H,I,J	10 ms - 10 days	SPDT	15	821TD10H-UNI
12-240 Vac/Vdc	A,B,C,D,E,F,G,H,I,J	10 ms - 10 days	DPDT	2 x 15 A (2 pairs of contacts)	822TD10H-UNI

(1) For function descriptions, see pages 33 and 34.

## Part Number Explanation

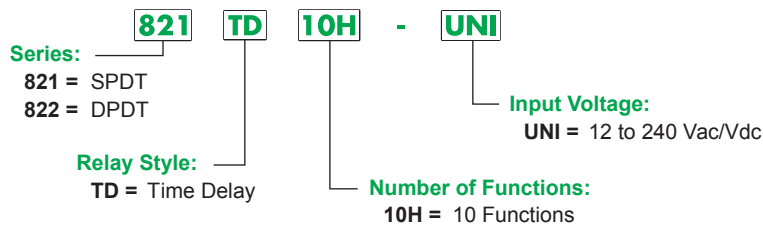

# Magnecraft™ Time Delay and Sensor Relays

820 Series

SPDT, 15 A; DPDT, 15 A

## Specifications

Part Number	821TD10H-UNI	822TD10H-UNI
<b>Input Characteristics</b>		
Input Voltage Range	12-240 Vac / Vdc	12-240 Vac / Vdc
Operating Voltage (% of Nominal)	85% of 12 V – 110% of 240 V	85% of 12 V – 110% of 240 V
Maximum Power Consumption	3 VA 1.7 W	3 VA 1.7 W
<b>Output Characteristics</b>		
Contact Configuration	SPDT	DPDT
Output Current Rating	15 A	15 A
Contact Material	Silver Alloy	Silver Alloy
Switching Capability	15 A @ 240 Vac, 50/60 Hz, 24 Vdc 1/2 HP @ 120 Vac 1 HP @ 240 Vac Pilot Duty B300	15 A @ 240 Vac, 50/60 Hz, 24 Vdc 1/2 HP @ 120 Vac 1 HP @ 240 Vac Pilot Duty B300
Minimum Switching Requirement	100 mA	100 mA
<b>Timing Characteristics</b>		
Functions Available (1)	All	All
Time Scales	8	8
Time Ranges	100 ms to 1 sec 1 sec to 10 sec 0.1 min to 1 min 1 min to 10 min 1 hr to 10 hrs 0.1 hr to 1 hrs 1 day to 10 day 0.1 day to 1 day	100 ms to 1 sec 1 sec to 10 sec 0.1 min to 1 min 1 min to 10 min 1 hr to 10 hrs 0.1 hr to 1 hrs 1 day to 10 day 0.1 day to 1 day
Tolerance	5% of Mechanical setting	5% of Mechanical setting
Repeatability @ constant voltage and temperature	0.2%	0.2%
Reset Time	150 ms maximum	150 ms maximum
Trigger Pulse Length	50 ms minimum	50 ms minimum
<b>General Characteristics</b>		
Electrical Life (operations at rated current) (2)	70,000 operations	70,000 operations
Mechanical Life (Unpowered) (2)	10,000,000 operations	10,000,000 operations
Dielectric Strength (Input to Contacts)	2500 Vac	2500 Vac
Dielectric Strength (Between Open Contacts)	1600 Vac	1600 Vac
Storage Temperature Range	-30°C (-22°F) to +70°C (+158°F)	-30°C (-22°F) to +70°C (+158°F)
Operating Temperature Range	-20°C (-4°F) to +55°C (+131°F)	-20°C (-4°F) to +55°C (+131°F)
Terminal Wire Capacity (Input and Output)	14 AWG (2.1 mm <sup>2</sup> ) maximum	14 AWG (2.1 mm <sup>2</sup> ) maximum
Terminal Screw Torque	7.1 lb-in (0.8 N•m) maximum	7.1 lb-in (0.8 N•m) maximum
Weight	55 g (1.9 oz)	70 g (2.5 oz)
Input Indication	Green LED	Green LED
Output Indication (Blinks = Timing or On = Energized)	Red LED	Red LED
Enclosure Rating (according to IEC 60529 IP rating)	IP20	IP20
Approvals	cULus (file no. E234203), CE 61810-1, RoHS	cULus (file no. E234203), CE 61810-1, RoHS

(1) For function descriptions, see pages 33 and 34.

(2) Actual product life will vary based on electrical load, duty cycle, application, and environmental conditions.

# Dimensions, Wiring Diagram

# Magnecraft™ Time Delay and Sensor Relays

820 Series  
SPDT, 15 A; DPDT, 15 A

## Dimensions — inches (millimeters)

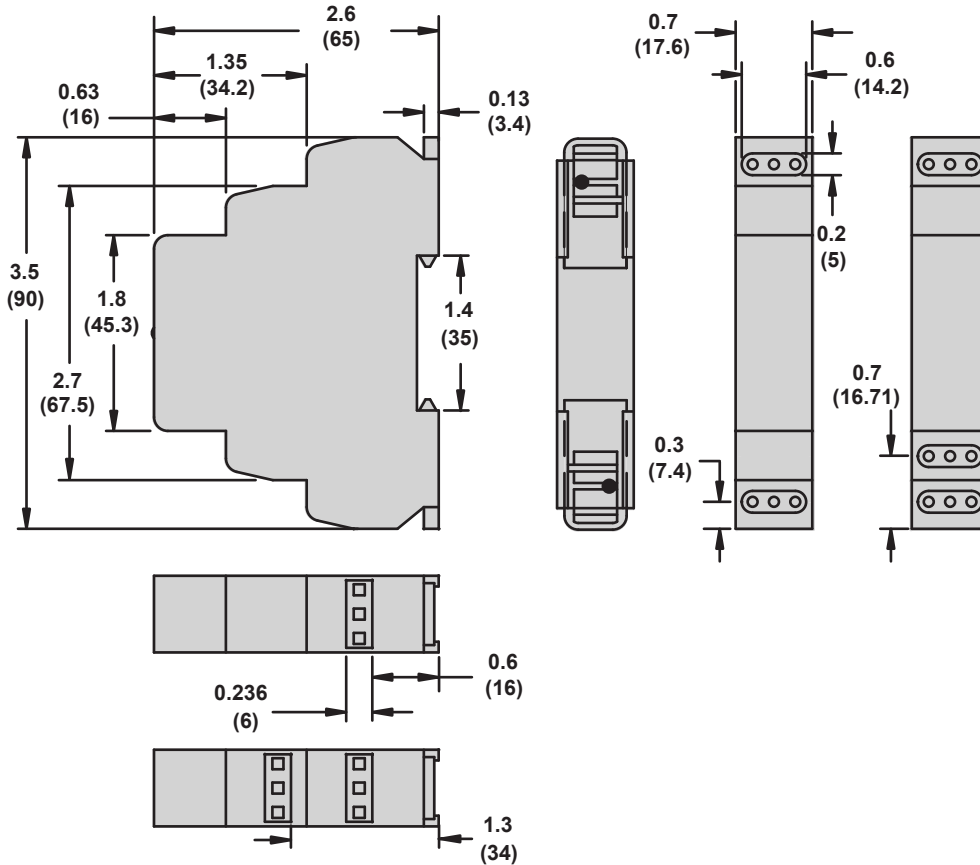

## Wiring Diagram

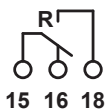
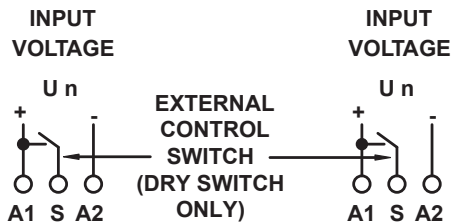

821TD10H-UNI

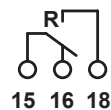
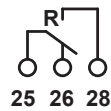
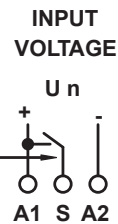

822TD10H-UNI

15 - COMMON  
16 - NORMALLY CLOSED  
18 - NORMALLY OPEN

25 - COMMON  
26 - NORMALLY CLOSED  
28 - NORMALLY OPEN

# Magnecraft™ Time Delay and Sensor Relays

831 Series  
SPDT, 15 A



831 Relay

## Description

The 831 voltage sensor is a single-phase AC voltage sensing device that is capable of monitoring and reacting to over and under voltage conditions. This product is designed to be wired across terminals A1 and A2 with the voltage that is being monitored. The two LED lamps indicate both when the input voltage is present (Green LED) and also when the output is energized (Red LED). The Umax dial is used to set the upper trip-point for the voltage sensor. The Umin dial is a percentage of the Umax dial and is used to set the lower trip-point for the voltage sensor. The timing dial is used to delay the transfer of the contacts, from 0 to 10 seconds, when a set point has been violated.

Feature	Benefit
3-state indication LEDs	Indicates normal state and 2 types of faulted states
Timing dial	Adjustable delay 0-10 sec
DIN mountable	Mounts directly on 35 mm DIN rail
Current rating is 15A @ 240 Vac, 24 Vdc	High switching capacity
Only 17.5 mm (0.69 in) wide	Ideal for tight spaces

Nominal Input Voltage	Sensing Voltage Range	Timing Range	Contact Configuration	Rated Current (A)	Standard Part Number
120 Vac	Upper: 85 to 150 Vac Lower: 30 to 99% of upper	0 sec - 10 sec	SPDT	15	831VS-120A
240 Vac	Upper: 160 to 276 Vac Lower: 30 to 99% of upper	0 sec - 10 sec	SPDT	15	831VS-240A
24 Vdc	Upper: 18 to 30 V Lower: 30 to 99% of upper	0 sec - 10 sec	SPDT	15	831VS-24D

## Part Number Explanation

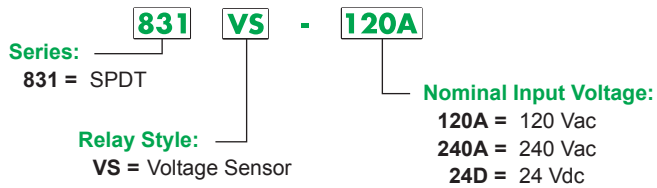

# Magnecraft™ Time Delay and Sensor Relays

831 Series  
SPDT, 15 A

## Specifications

Part Number	831VS-120A	831VS-240A	831VS-24D
<b>Input Characteristics</b>			
Nominal Input Voltage	120 Vac	240 Vac	24 Vdc
Absolute Input Voltage Maximum	200 Vac	280 Vac	35 Vdc
Upper Supply Voltage Range	85 to 150 Vac	160 to 276 Vac	18 to 30 Vdc
Lower Supply Voltage Range	30 to 99% of upper preset	30 to 99% of upper preset	30 to 99% of upper preset
Maximum Power Consumption	1.2 VA	1.2 VA	1.2 W
Time Delay	adjustable 0 to 10 sec	adjustable 0 to 10 sec	adjustable 0 to 10 sec
<b>Accuracy</b>			
Mechanical Setting	5%	5%	5%
Repeat Accuracy	<1%	<1%	<1%
Temperature Variation	<1% / °C	<1% / °C	<1% / °C
Hysteresis (from fault to normal)	2 to 6% of adjusted value	2 to 6% of adjusted value	2 to 6% of adjusted value
<b>Output Characteristics</b>			
Contact Configuration	1C / SPDT	1C / SPDT	1C / SPDT
Output Current Rating	15 A @ 120, 240 Vac, 24 Vdc	15 A @ 120, 240 Vac, 24 Vdc	15 A @ 120, 240 Vac, 24 Vdc
Breaking Capacity	4000 VA/AC1, 384 W/DC	4000 VA/AC1, 384 W/DC	4000 VA/AC1, 384 W/DC
Inrush Current	30 A / <3 sec	30 A / <3 sec	30 A / <3 sec
Maximum Switching Voltage	250 Vac / 24 Vdc	250 Vac / 24 Vdc	250 Vac / 24 Vdc
Minimum Breaking Capacity DC	500 mW	500 mW	500 mW
Mechanical Life	3.00E+07	3.00E+07	3.00E+07
Electrical Life	7.00E+04	7.00E+04	7.00E+04
Contact Material	Silver Alloy	Silver Alloy	Silver Alloy
Switching Capability	15 A @ 240 Vac, 50/60 Hz, 24 Vdc 1/2 HP @ 120 Vac 1 HP @ 240 Vac Pilot Duty B300	15 A @ 240 Vac, 50/60 Hz, 24 Vdc 1/2 HP @ 120 Vac 1 HP @ 240 Vac Pilot Duty B300	15 A @ 240 Vac, 50/60 Hz, 24 Vdc 1/2 HP @ 120 Vac 1 HP @ 240 Vac Pilot Duty B300
Minimum Switching Requirement	100 mA at 5 Vac or Vdc	100 mA at 5 Vac or Vdc	100 mA at 5 Vac or Vdc
<b>Timing/Sensing Characteristics</b>			
Time Scales	1	1	1
Time Ranges	0 sec to 10 sec	0 sec to 10 sec	0 sec to 10 sec
Tolerance	5% of Mechanical setting	5% of Mechanical setting	5% of Mechanical setting
Repeatability @ constant voltage and temperature	1%	1%	1%
Upper Sensing Voltage Range	85 to 150 Vac	160 to 276 Vac	18 to 30 Vdc
Lower Sensing Voltage Range	30 to 99% of upper preset	30 to 99% of upper preset	30 to 99% of upper preset
<b>General Characteristics</b>			
Dielectric Strength (Input to Contacts)	2.5 kV (I/O)	2.5 kV (I/O)	2.5 kV (I/O)
Dielectric Strength (Between Open Contacts)	1600 Vac	1600 Vac	1600 Vac
Mounting Position	Any, 35 mm DIN rail EN 50022	Any, 35 mm DIN rail EN 50022	Any, 35 mm DIN rail EN 50022
Overvoltage Category	III	III	III
Pollution Degree	2	2	2
Storage Temperature Range	-30°C (-22°F) to +70°C (+158°F)	-30°C (-22°F) to +70°C (+158°F)	-30°C (-22°F) to +55°C (+131°F)
Operating Temperature Range	-20°C (-4°F) to +55°C (+131°F)	-20°C (-4°F) to +55°C (+131°F)	-20°C (-4°F) to +55°C (+131°F)
Terminal Wire Capacity (Input and Output)	14 AWG (2.5 mm <sup>2</sup> ) maximum	14 AWG (2.5 mm <sup>2</sup> ) maximum	14 AWG (2.5 mm <sup>2</sup> ) maximum
Terminal Screw Torque	7.1 Lb-in (0.8 N•m) maximum	7.1 Lb-in (0.8 N•m) maximum	7.1 Lb-in (0.8 N•m) maximum
Weight	62 g (2.19 oz)	62 g (2.19 oz)	88 g (3.10 oz)
Input Indication	Green LED	Green LED	Green LED
Output Indication (Blinks = Timing or On = Energized)	Red LED	Red LED	Red LED
Enclosure Rating (according to IEC 60529 IP rating)	IP40	IP40	IP40
Approvals	UL (E234203), CE (IEC 60947-1, 61000-4), RoHS	UL (E234203), CE (IEC 60947-1, 61000-4), RoHS	UL (E234203), CE (IEC 60947-1, 61000-4), RoHS

(1) Actual product life will vary based on electrical load, duty cycle, application, and environmental conditions.



**Dimensions — inches (millimeters)**

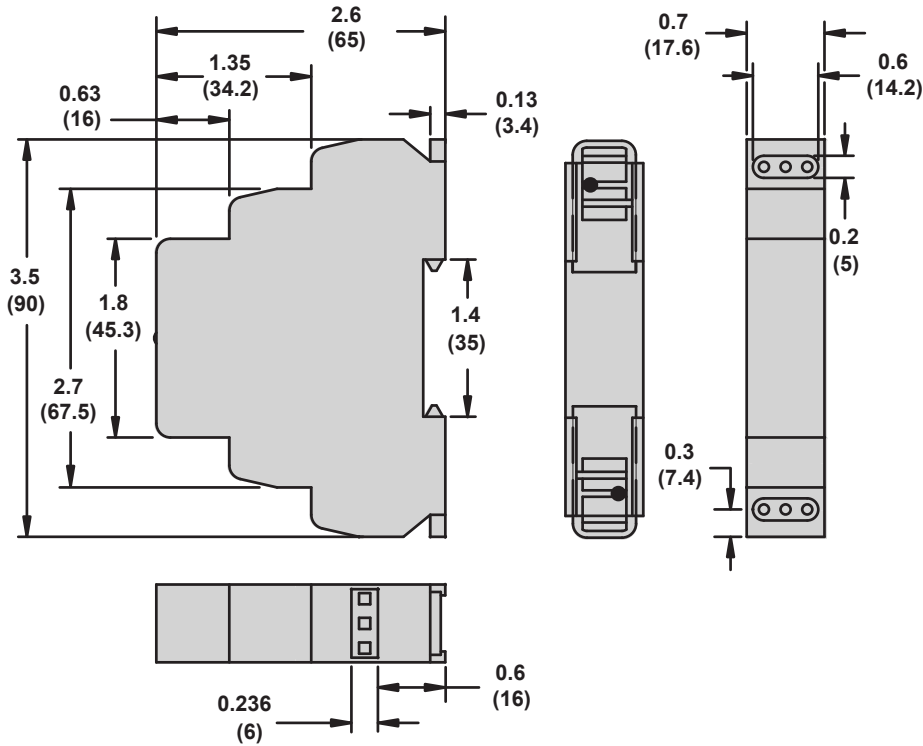

**Wiring Diagram**

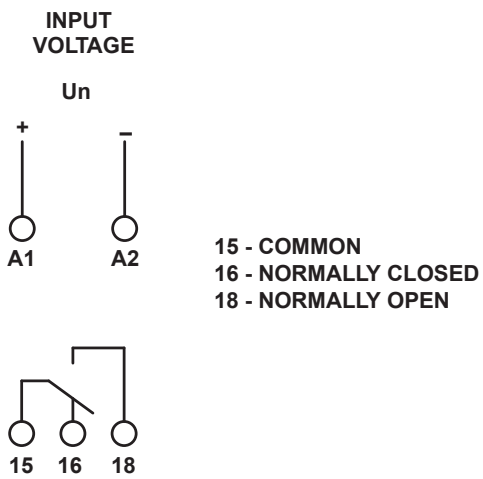

## Description

# Magnecraft™ Time Delay and Sensor Relays

841 Series  
SPDT, 15 A



841 Relay

## Description

Current sensing relay which allows the user to monitor the current of one circuit (1 to 8 A) and switch another circuit in case of an over current condition; all in a modular, Fingersafe™ (according to IEC 60529 IP rating) package.

Feature	Benefit
Current sensing adjustment knob	Sense anywhere from 10% to 100% of the rated sensing current
Input/output terminals	Accepts up to a 14 AWG Wire
Solid state circuitry	Used for precise sensing and timing control
Input/output indication	Shows status at a glance
DIN rail mountable	Mounts directly on a DIN Rail
Only 17.5 mm (0.69 in) wide	Ideal for tight spaces
Wide input range	Enabled to work with common AC voltages.

Input Voltage	Sensing Current Range (AC)	Timing Range	Contact Configuration	Output (A)	Standard Part Number
24 to 240 Vac	100 mA to 1 A	100 ms to 10 sec	SPDT	15 A	841CS1-UNI
24 to 240 Vac	200 mA to 2 A	100 ms to 10 sec	SPDT	15 A	841CS2-UNI
24 to 240 Vac	500 mA to 5 A	100 ms to 10 sec	SPDT	15 A	841CS5-UNI
24 to 240 Vac	800 mA to 8 A	100 ms to 10 sec	SPDT	15 A	841CS8-UNI

## Part Number Explanation

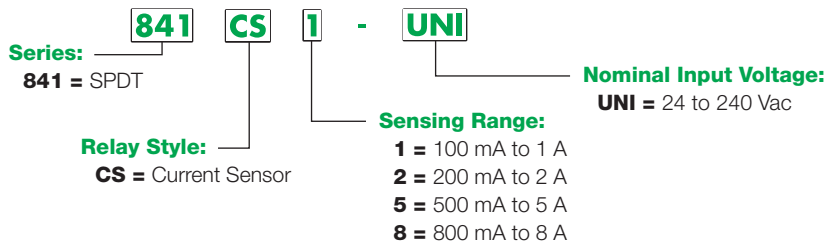

# Magnecraft™ Time Delay and Sensor Relays

## 841 Series

### SPDT, 15 A

## Specifications

Part Number	841CS1-UNI	841CS2-UNI	841CS5-UNI	841CS8-UNI
<b>Input Characteristics</b>				
Input Voltage Range	24 to 240 Vac	24 to 240 Vac	24 to 240 Vac	24 to 240 Vac
Maximum Power Consumption	1.2 VA	1.2 VA	1.2 VA	1.2 VA
<b>Output Characteristics</b>				
Contact Configuration	SPDT	SPDT	SPDT	SPDT
Output Current Rating	15 A	15 A	15 A	15 A
Contact Material	Silver Alloy	Silver Alloy	Silver Alloy	Silver Alloy
Switching Capability	15A @ 240 Vac, 50/60 Hz, 24 Vdc 1/2 HP @ 120 Vac 1 HP @ 240 Vac Pilot Duty B300	15A @ 240 Vac, 50/60 Hz, 24 Vdc 1/2 HP @ 120 Vac 1 HP @ 240 Vac Pilot Duty B300	15A @ 240 Vac, 50/60 Hz, 24 Vdc 1/2 HP @ 120 Vac 1 HP @ 240 Vac Pilot Duty B300	15A @ 240 Vac, 50/60 Hz, 24 Vdc 1/2 HP @ 120 Vac 1 HP @ 240 Vac Pilot Duty B300
Minimum Switching Requirement	100 mA at 5 Vac or Vdc	100 mA at 5 Vac or Vdc	100 mA at 5 Vac or Vdc	100 mA at 5 Vac or Vdc
<b>Timing/Sensing Characteristics</b>				
Time Scales	1	1	1	1
Time Ranges	0 sec to 10 sec	0 sec to 10 sec	0 sec to 10 sec	0 sec to 10 sec
Tolerance	5% of Mechanical setting	5% of Mechanical setting	5% of Mechanical setting	5% of Mechanical setting
Repeatability @ constant voltage and temperature	1%	1%	1%	1%
Sensing Range	100 mA to 1 A	200 mA to 2 A	500 mA to 5 A	800 mA to 8 A
<b>General Characteristics</b>				
Electrical Life (operations at rated current) (1)	70,000 operations	70,000 operations	70,000 operations	70,000 operations
Mechanical Life (Unpowered) (1)	10,000,000 operations	10,000,000 operations	10,000,000 operations	10,000,000 operations
Dielectric Strength (Input to Contacts)	2500 Vac	2500 Vac	2500 Vac	2500 Vac
Dielectric Strength (Between Open Contacts)	1600 Vac	1600 Vac	1600 Vac	1600 Vac
Storage Temperature Range	-30°C (-22°F) to +70°C (+158°F)	-30°C (-22°F) to +70°C (+158°F)	-30°C (-22°F) to +70°C (+158°F)	-30°C (-22°F) to +70°C (+158°F)
Operating Temperature Range	-20°C (-4°F) to +55°C (+131°F)	-20°C (-4°F) to +55°C (+131°F)	-20°C (-4°F) to +55°C (+131°F)	-20°C (-4°F) to +55°C (+131°F)
Terminal Wire Capacity (Input and Output)	14 AWG (2.1 mm <sup>2</sup> ) maximum	14 AWG (2.1 mm <sup>2</sup> ) maximum	14 AWG (2.1 mm <sup>2</sup> ) maximum	14 AWG (2.1 mm <sup>2</sup> ) maximum
Terminal Screw Torque	7.1 Lb-in (0.8 N•m) maximum	7.1 Lb-in (0.8 N•m) maximum	7.1 Lb-in (0.8 N•m) maximum	7.1 Lb-in (0.8 N•m) maximum
Weight	60 g (2.12 oz)	60 g (2.12 oz)	60 g (2.12 oz)	60 g (2.12 oz)
Input Indication	Green LED	Green LED	Green LED	Green LED
Output Indication (Blinks = Timing or On = Energized)	Red LED	Red LED	Red LED	Red LED
Enclosure Rating (according to IEC 60529 IP rating)	IP20	IP20	IP20	IP20
Approvals	cULus (File No. E234203), CE 61810-1, RoHS	cULus (File No. E234203), CE 61810-1, RoHS	cULus (File No. E234203), CE 61810-1, RoHS	cULus (File No. E234203), CE 61810-1, RoHS

(1) Actual product life will vary based on electrical load, duty cycle, application, and environmental conditions.

## Dimensions — inches (millimeters)

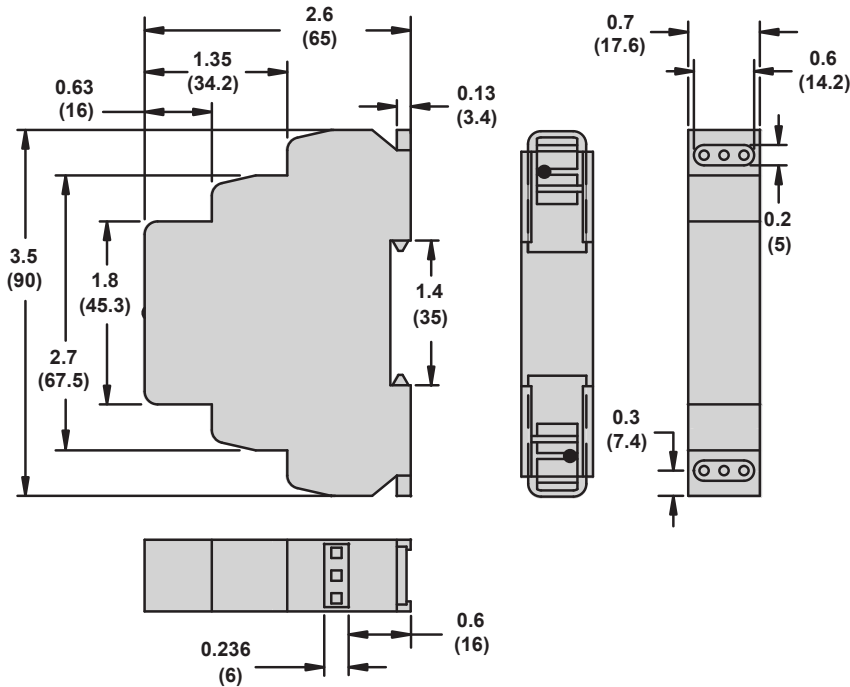

## Wiring Diagram

Wiring for direct current sensing:

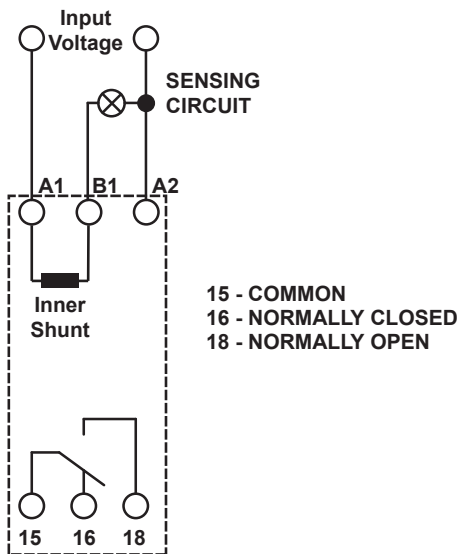

Wiring for current sensing through current transformer:

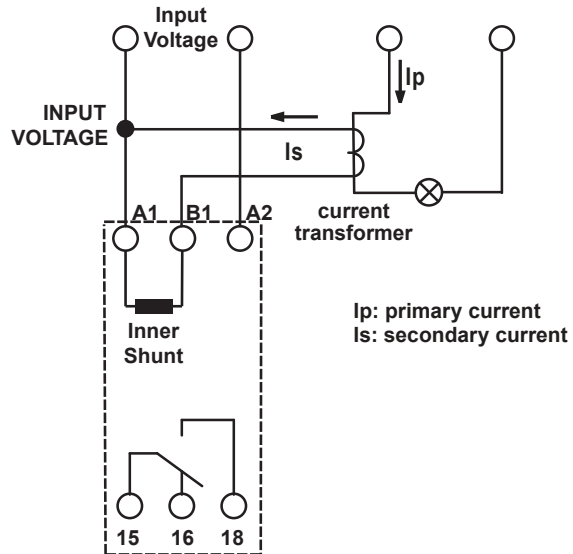

# Magnecraft™ Time Delay and Sensor Relays

## 800 Series Accessories

### Description

The 16-700DIN DIN Rail provides quick removable and installations of most sockets and the 16-788C1 panel adapter provides a panel mounting option.

16-700DIN DIN Rail

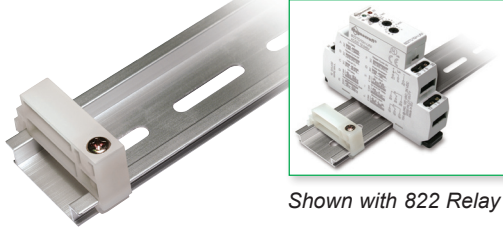

Shown with 822 Relay

16-788C1 Panel Adapter

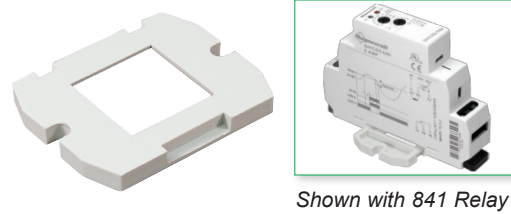

Shown with 841 Relay

Description	Function	For Use With Relays	Packaging Quantities	Standard Part Number
Metal DIN Rail	Quick installation and removable	821, 822, 831, 841	10 (1)	16-700DIN
Panel Adapter	Provides additional panel mount option.	821, 822, 831, 841	10	16-788C1

(1) Length is 39.3 inches.

### Dimensions — inches (millimeters)

16-700DIN Metal DIN Rail

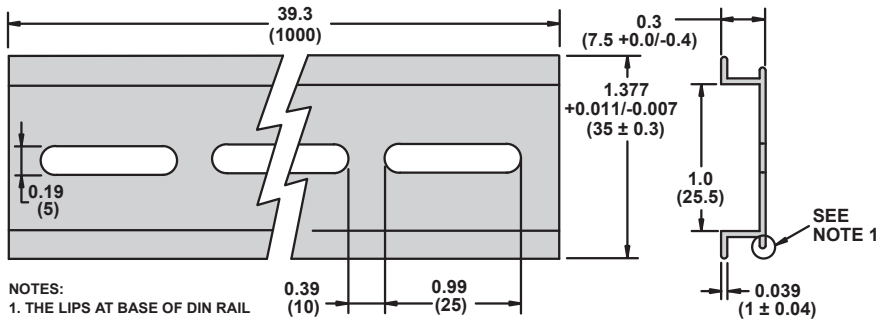

NOTES:  
1. THE LIPS AT BASE OF DIN RAIL MAY OR MAY NOT BE PRESENT ON DIN RAIL EXTRUSIONS.

16-788C1 Panel Mount Adapter

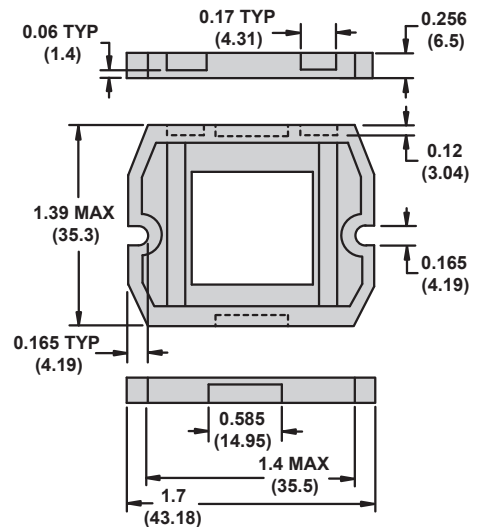

## Description

# Magnecraft™ Time Delay and Sensor Relays

TDR782 Series

DPDT, 5 A; 4PDT, 3 A



TDR782 Relay

## Description

Miniature time delay relay that is single-function, single-voltage and socket-compatible. Ideal for tight spaces.

Feature	Benefit
Time setting	Select between 7 different time scales
Socket compatible	Mounts directly to DIN Rail or Panel
Input/Output indication	Shows status at a glance
Time adjustment dial	Fine tune the time setting
IEC and NEMA terminal numbering	For numbering compatibility

Input Voltage	Functions Available (1)	Timing Range	Contact Configuration	Rated Current (A)	Standard Part Number
110 Vac	A (On Delay)	100 ms to 100 hrs	DPDT	5 A	TDR782XBXA-110A
24 Vac	A (On Delay)	100 ms to 100 hrs	DPDT	5 A	TDR782XBXA-24A
24 Vdc	A (On Delay)	100 ms to 100 hrs	DPDT	5 A	TDR782XBXA-24D
110 Vac	A (On Delay)	100 ms to 100 hrs	4PDT	3 A	TDR782XDXA-110A
12 Vdc	A (On Delay)	100 ms to 100 hrs	4PDT	3 A	TDR782XDXA-12D
230 Vac	A (On Delay)	100 ms to 100 hrs	4PDT	3 A	TDR782XDXA-230A
24 Vac	A (On Delay)	100 ms to 100 hrs	4PDT	3 A	TDR782XDXA-24A
24 Vdc	A (On Delay)	100 ms to 100 hrs	4PDT	3 A	TDR782XDXA-24D

(1) For function descriptions, see pages 33 and 34.

## Part Number Explanation

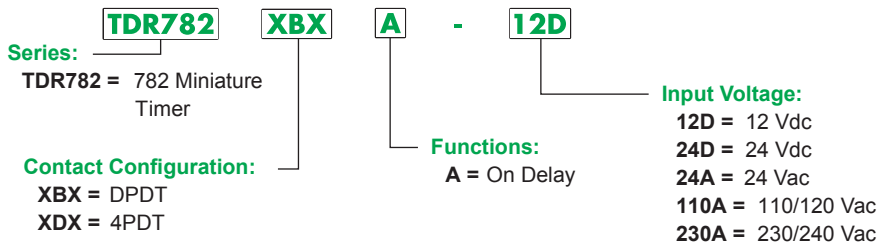

# Magnecraft™ Time Delay and Sensor Relays

TDR782 Series  
DPDT, 5 A; 4PDT, 3 A

## Specifications

Part Number	TDR782XBX	TDR782XDX
<b>Input Characteristics</b>		
Input Voltage Range	24, 110/120, 230/240 Vac 12, 24 Vdc	24, 110/120, 230/240 Vac 12, 24 Vdc
Operating Voltage (Vac)	85% to 115% of Nominal	85% to 115% of Nominal
Operating Voltage (Vdc)	90% to 110% of Nominal	90% to 110% of Nominal
Maximum Power Consumption	1.7 VA @ 24 Vac 2.6 VA @ 120 Vac 3 VA @ 230 Vac 1.5 W @ 12 Vdc 1.2 W @ 24 Vdc	1.7 VA @ 24 Vac 2.6 VA @ 120 Vac 3 VA @ 230 Vac 1.5 W @ 12 Vdc 1.2 W @ 24 Vdc
<b>Output Characteristics</b>		
Contact Configuration	DPDT	4PDT
Contacts Current Rating	5 A	3 A
Contact Material	Silver Alloy	Silver Alloy
Maximum inrush current	10A @ < 100 ms	10A @ < 100 ms
Minimum Switching Requirement	100 mA at 5 Vac or Vdc	100 mA at 5 Vac or Vdc
<b>Timing Characteristics</b>		
Functions Available (1)	A (On Delay)	A (On Delay)
Time Scales	7	7
Time Ranges	100 ms to 1 sec 1 sec to 10 sec 0.1 min to 1 min 1 min to 10 min 0.1 hr to 1 hr 1 hr to 10 hrs 10 hr to 100 hrs	100 ms to 1 sec 1 sec to 10 sec 0.1 min to 1 min 1 min to 10 min 0.1 hr to 1 hr 1 hr to 10 hrs 10 hr to 100 hrs
Tolerance	5% of Mechanical setting	5% of Mechanical setting
Repeatability @ constant voltage and temperature	0.5%	0.5%
Reset Time	50 ms maximum	50 ms maximum
Temperature Drift	0.05 % / °C	0.05 % / °C
<b>General Characteristics</b>		
Electrical Life (operations at rated current) (2)	100,000 operations	100,000 operations
Mechanical Life (Unpowered) (2)	10,000,000 operations	10,000,000 operations
Dielectric Strength (Input to Contacts)	2000 Vrms	2000 Vrms
Storage Temperature Range	-40°C (-40°F) to +70°C (+158°F)	-40°C (-40°F) to +70°C (+158°F)
Operating Temperature Range	-20°C (-4°F) to +60°C (+140°F)	-20°C (-4°F) to +60°C (+140°F)
Weight	43 g (1.52 oz)	43 g (1.52 oz)
Input Indication	Green LED	Green LED
Output Indication (On = Energized)	Amber LED	Amber LED
Enclosure Rating (according to IEC 60529 IP rating)	IP50	IP50
Approvals	cURus (File No. E191122), CSA (File No. 254373), CE 61810-1, RoHS	cURus (File No. E191122), CSA (File No. 254373), CE 61810-1, RoHS

(1) For function descriptions, see pages 33 and 34.

(2) Actual product life will vary based on electrical load, duty cycle, application, and environmental conditions.

## Dimensions, Wiring Diagram

# Magnecraft™ Time Delay and Sensor Relays

TDR782 Series  
DPDT, 5 A; 4PDT, 3 A

### Dimensions — inches (millimeters)

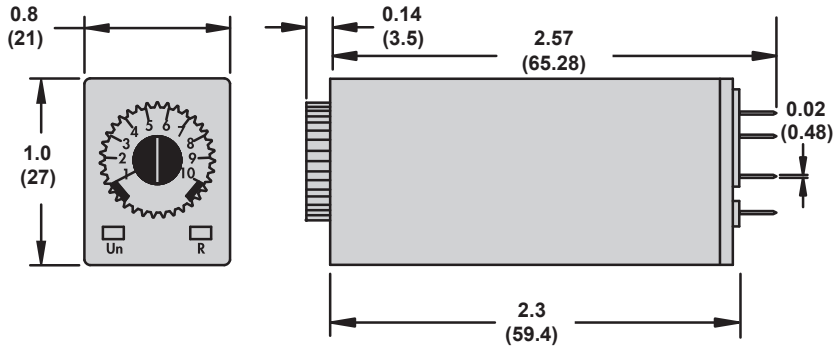

### Wiring Diagram

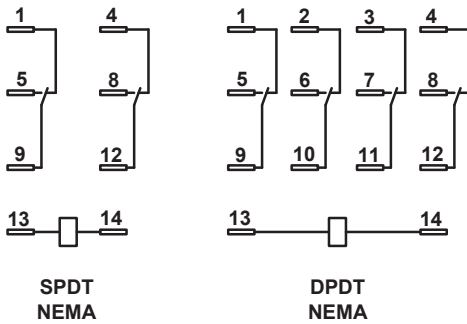



# Magnecraft™ Time Delay and Sensor Relays

## TDR782 Series Accessories

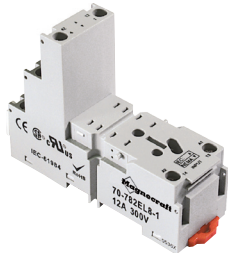

70-782EL8-1 Socket



70-782EL14-1 Socket

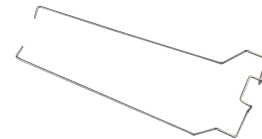

16-TDR782SC Spring Clip

### Description

The TDR782 accessories create a complete system solution for all your application needs. The 70-782EL socket offers an alternate installation option for plug-in models. The 16-TDR782SC retention clip holds the relay securely in place while allowing quick and efficient installation and maintenance.

### Relay Accessories

Description	Function	For Use With Relays	Packaging Quantities	Standard Part Number
Socket	Mounts directly to DIN Rail or Panel	TDR782XBX	10	70-782EL8-1
Socket	Mounts directly to DIN Rail or Panel	TDR782XBX TDR782XDX	10	70-782EL14-1
Socket	DIN/Panel Mount with Rising Elevator Box Terminals	TDR782XBX TDR782XDX	10	70-782E14-1
Socket	DIN/Panel Mount with Screw Terminals & Clamping Plates	TDR782XBX TDR782XDX	10	70-782D14-1
Socket	DIN/Panel Mount with Screw Terminals & Clamping Plates	TDR782XBX TDR782XDX	10	70-461-1
Socket	Solder Terminals for Chassis mount	TDR782XBX TDR782XDX	10	70-378-1
Socket	Printed Circuit Terminals	TDR782XBX TDR782XDX	10	70-379-1
Metal Hold-Down Clip	Helps secure relay in socket	TDR782●●	10	16-TDR782SC

### Socket Accessories

Description	Function	For Use With Sockets	Packaging Quantities	Standard Part Number
Metal DIN Rail	Quick installation and removable of sockets	(See table above.)	10 (1)	16-700DIN
ID Tags	Allows for identification of circuits in multi-relay applications	70-782EL8-1 70-782EL14-1 70-782E14-1	10	16-782FT-1

(1) Length is 39.3 inches.

# Magnecraft™ Time Delay and Sensor Relays

## TDR782 Series Accessories

### Specifications

Part Number	70-782EL8-1, 70-782EL14-1	70-782EL14-1	70-782E14-1
Contact Configuration	DPDT	4PDT	4PDT
Number of Terminals	8	14	14
Mounting Style	Panel/DIN Rail	Panel/DIN Rail	Panel/DIN Rail
Current Rating	12 A	10 A	10 A
Nominal Voltage Rating	300 V	300 V	300 V
Storage temperature Range	-40°C (-40°F) to +105°C (+221°F)	-40°C (-40°F) to +105°C (+221°F)	-40°C (-40°F) to +105°C (+221°F)
Protection Category (Fingersafe™)	IP 20	IP 20	IP 20
Internal Metal Tracks	Copper Alloy, Zinc Plated	Copper Alloy, Zinc Plated	Copper Alloy, Zinc Plated
Screw Terminals	Steel, Zinc Plated	Steel, Zinc Plated	Steel, Zinc Plated
Screw Style	Combination Head	Combination Head	Combination Head
Screw Size	M3	M3	M3
Terminal Connection	Elevator	Elevator	Elevator
Terminal Layout	Logic	Logic	Non-Logic
Wire Size Capacity	Solid Cu 14 / 16 (2) AWG, 2.5 / 1.5 (2) mm <sup>2</sup> Stranded Cu 14 / 16 (2) AWG, 2.5 / 1.5 (2) mm <sup>2</sup>	Solid Cu 14 / 16 (2) AWG, 2.5 / 1.5 (2) mm <sup>2</sup> Stranded Cu 14 / 16 (2) AWG, 2.5 / 1.5 (2) mm <sup>2</sup>	Solid Cu 14 / 16 (2) AWG, 2.5 / 1.5 (2) mm <sup>2</sup> Stranded Cu 14 / 16 (2) AWG, 2.5 / 1.5 (2) mm <sup>2</sup>
DIN Rail Mounting, EN 60715	35 mm (1.38 in)	35 mm (1.38 in)	35 mm (1.38 in)
Maximum Screw Torque	7 lb-in (0.8 N•m)	7 lb-in (0.8 N•m)	7 lb-in (0.8 N•m)
Flammability Rating	94V-0 Class	94V-0 Class	94V-0 Class
Body Color	Light Gray	Light Gray	Light Gray
DIN Locking Method	Red Plastic Locking Clip	Red Plastic Locking Clip	Metal Compression Spring
Product Certifications	cURus (File No. E70550), CSA (File No. 40787), CE 60947-1, RoHS	cURus (File No. E70550), CSA (File No. 40787), CE 60947-1, RoHS	cURus (File No. E70550), CSA (File No. 40787), CE 60947-1, RoHS

Part Number	70-379-1	70-378-1	70-461-1, 70-782D14-1
Contact Configuration	4PDT	4PDT	4PDT
Number of Terminals	14	14	14
Mounting Style	PCB	Chassis	Panel/DIN Rail
Current Rating	5A	5A	10A
Nominal Voltage Rating	300 V	300 V	300 V
Storage temperature Range	-40°C (-40°F) to +105°C (+221°F)	-40°C (-40°F) to +105°C (+221°F)	-40°C (-40°F) to +105°C (+221°F)
Protection Category (Fingersafe™)	–	–	IP 20 (for 70-782D14-1)
Internal Metal Tracks	Copper Alloy, Zinc Plated	Copper Alloy, Zinc Plated	Copper Alloy, Zinc Plated
Screw Terminals	Copper Alloy, Zinc Plated	Copper Alloy, Zinc Plated	Steel, Zinc Plated
Screw Style	–	–	Combination Head
Screw Size	–	–	M3 mm
Terminal Connection	PCB	Solder	Screw Clamping
Terminal Layout	Non Logic	Non Logic	Non-Logic
Wire Size Capacity	–	Solid Cu 14 / 16 (2) AWG, 2.5 / 1.5 (2) mm <sup>2</sup> Stranded Cu 14 / 16 (2) AWG, 2.5 / 1.5 (2) mm <sup>2</sup>	Solid Cu 14 / 16 (2) AWG, 2.5 / 1.5 (2) mm <sup>2</sup> Stranded Cu 14 / 16 (2) AWG, 2.5 / 1.5 (2) mm <sup>2</sup>
DIN Rail Mounting, EN 60715	–	–	35 mm (1.38 in)
Maximum Screw Torque	–	–	7 lb-in (0.8 N•m)
Flammability Rating	94V-0 Class	94V-0 Class	94V-0 Class
Body Color	Light Gray	Light Gray	Light Gray
DIN Locking Method	–	–	Red Plastic Locking Clip
Product Certifications	cURus (File No. E70550), CSA (File No. 97899), CE 60947-1, RoHS	cURus (File No. E70550), CSA (File No. 97899), CE 60947-1, RoHS	<b>70-461-1:</b> cURus (File No. E70550), CSA (File No. 97899), CE 60947-1, RoHS <b>70-782D14-1:</b> cURus (File No. E70550), CSA (File No. 40787), CE 60947-1, RoHS

# Magnecraft™ Time Delay and Sensor Relays

## TDR782 Series Accessories

### Dimensions — inches (millimeters)

**70-782EL8-1**

Mounts directly to DIN Rail or Panel

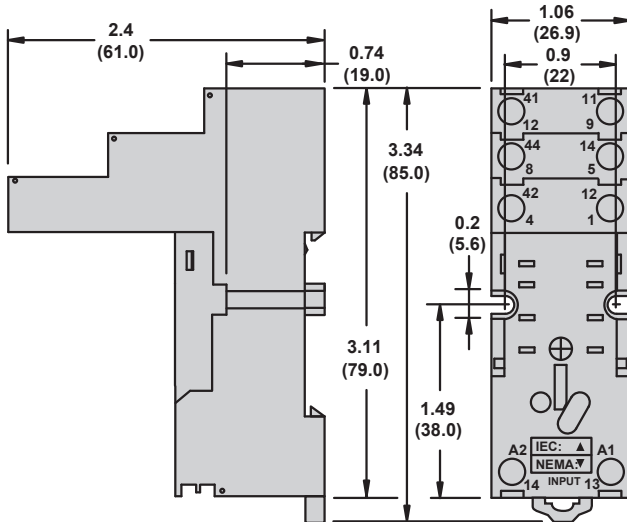

**70-782EL14-1**

Mounts directly to DIN Rail or Panel

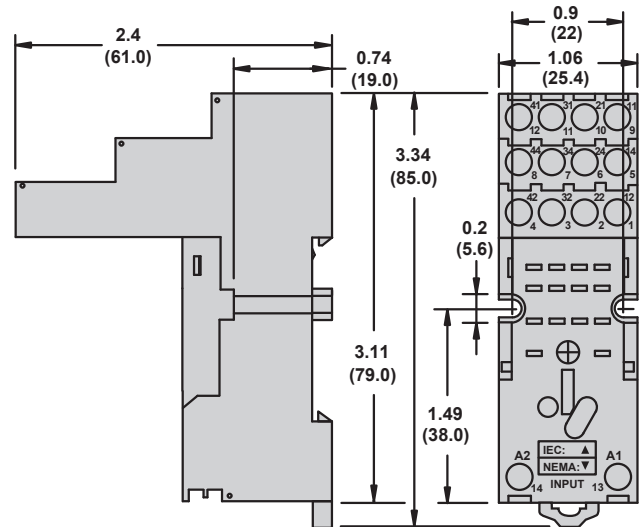

**70-782E14-1**

DIN/Panel Mount with Rising Elevator Box Terminals

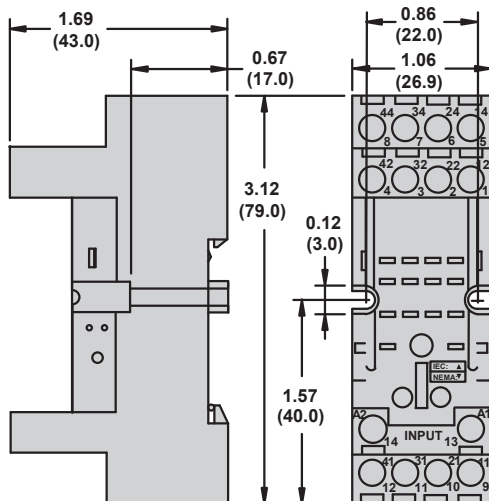

**70-782D14-1**

DIN/Panel Mount with Screw Terminals and Clamping Plates

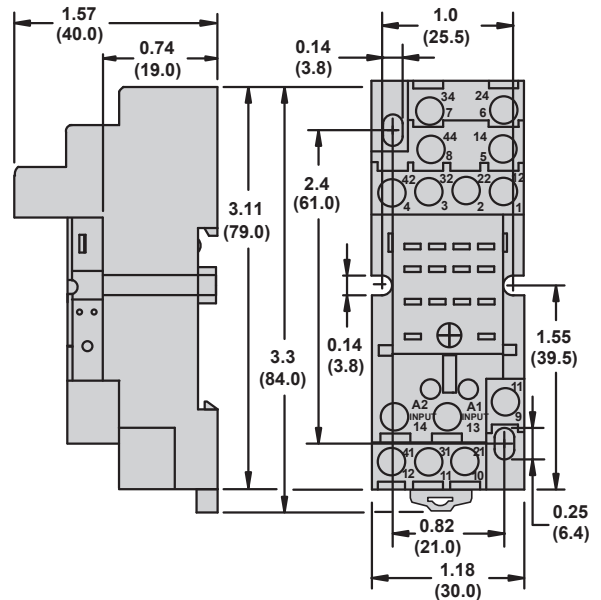

### Dimensions — inches (millimeters)

#### 70-461-1

DIN/Panel Mount with Screw Terminals and Clamping Plates

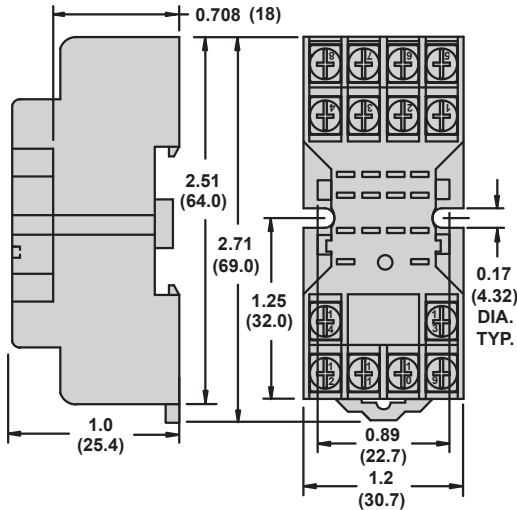

#### 70-378-1

Solder Terminals for Chassis Mount

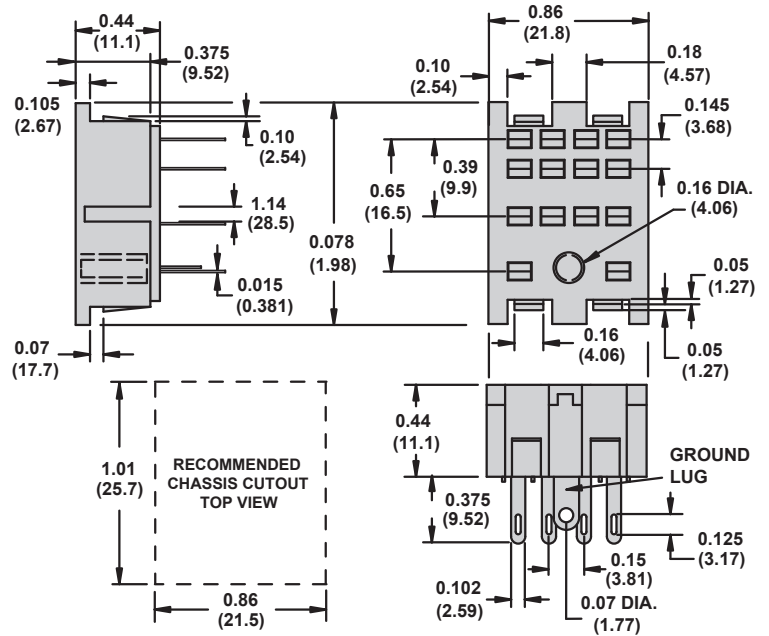

#### 70-379-1

Printed Circuit Terminals

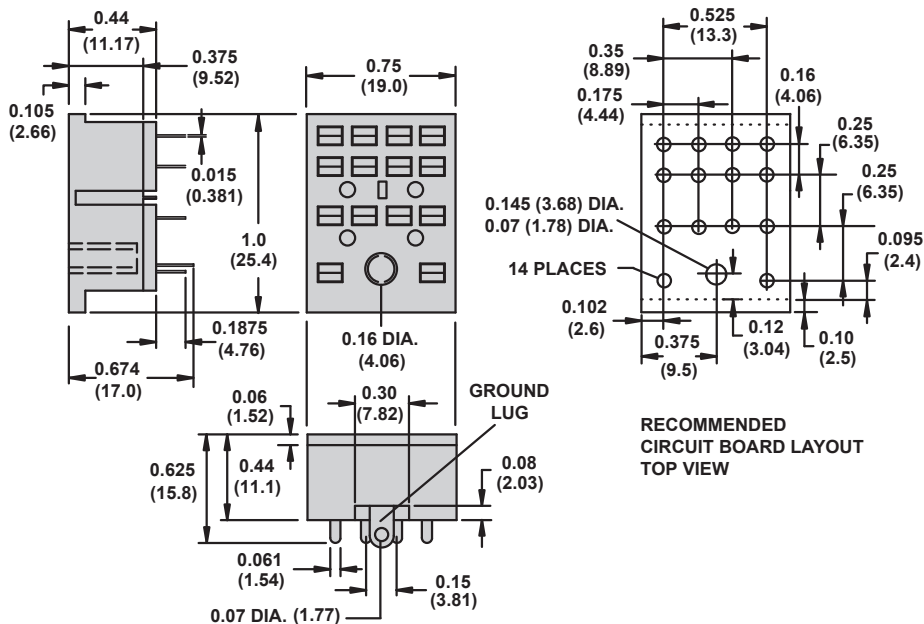

## Wiring Diagrams

70-782EL8-1

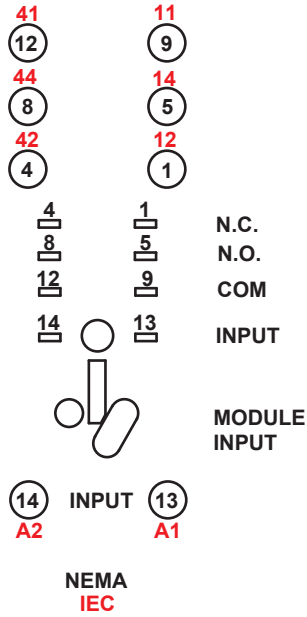

70-782EL14-1

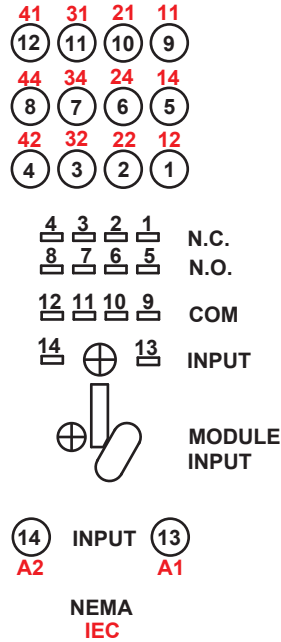

70-782E14-1

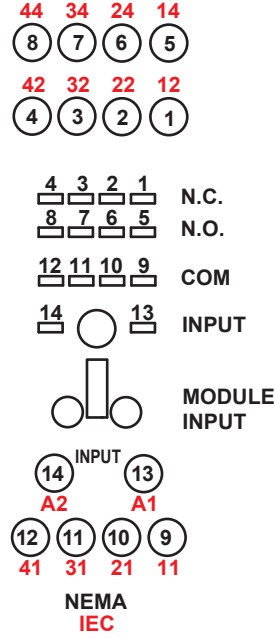

70-782D14-1

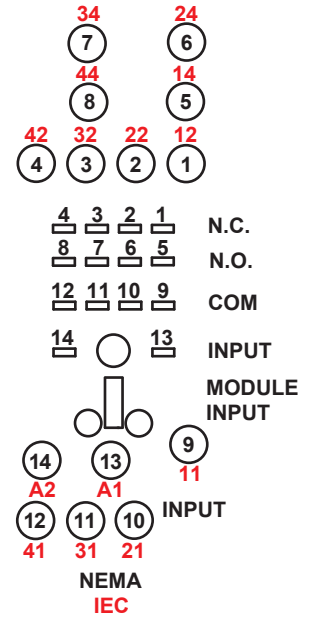

70-461-1

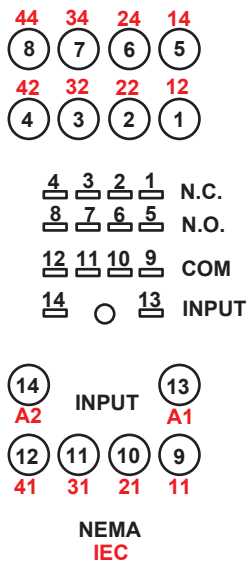

70-378-1

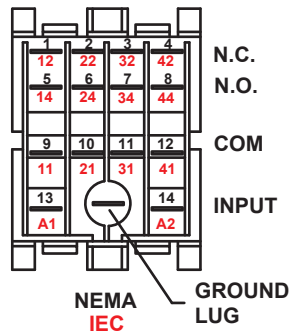

70-379-1

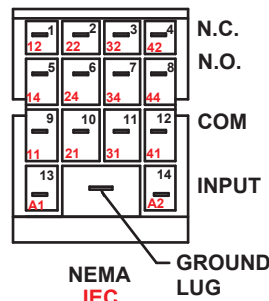

## Description

# Magnecraft™ Time Delay and Sensor Relays

TDRPRO Series  
SPDT, 12 A; DPDT, 12 A



TDRPRO Relay

## Description

Time delay relays that are programmable, multi-function, multi-voltage, and socket-compatible - offering the user the ultimate in design flexibility. The thumb wheel adjustment dials result in no mechanical deviation for supreme accuracy.

Feature	Benefit
Up to 10 functions	5 Timing functions controlled via supply voltage 4 Timing functions controlled via trigger input 1 function of memory latching
Broad timing range	0.1 Seconds to 9990 hours
Panel mount adapter	Panel mountable
Dust cover	Retains settings / keeps dust out
Universal power supply	12 – 240 Vac/Vdc
Thumb wheel adjustment for function / timing	Helps ensure accuracy and reduces timing deviations
2 LED status indicators	Indicate coil power / timing out / output state
RoHS compliant	Environmentally friendly

Input Voltage	Functions Available (1)	Timing Range	Contact Configuration	Rated Current (A)	Standard Part Number
12 to 240 Vac/Vdc	A,B,C,D,E,F,G,H,I,J	100 ms to 9990 hrs	DPDT	12	TDRPRO-5100
12 to 240 Vac/Vdc	A,B,C,D,E,F,G,H,I,J	100 ms to 9990 hrs	SPDT	12	TDRPRO-5101
12 to 240 Vac/Vdc	A,B,C	100 ms to 9990 hrs	DPDT	12	TDRPRO-5102

(1) For function descriptions, see pages 33 and 34.

## Part Number Explanation

Series: **TDRPRO** - **5100**

**TDRPRO** = 48 x 48 mm Time Delay Relay

**Contact Configuration/# of Functions:**

- 5100** = DPDT, 10 Functions
- 5101** = SPDT, 10 Functions
- 5102** = DPDT, 3 Functions

# Magnecraft™ Time Delay and Sensor Relays

## TDRPRO Series

### SPDT, 12 A; DPDT, 12 A

## Specifications

Part Number	TDRPRO-5100	TDRPRO-5101	TDRPRO-5102
<b>Input Characteristics</b>			
Input Voltage Range	12 to 240 Vac/Vdc	12 to 240 Vac/Vdc	12 to 240 Vac/Vdc
Operating Voltage	85% to 115% of Nominal	85% to 115% of Nominal	85% to 115% of Nominal
Maximum Power Consumption (AC)	2.5 VA	2.5 VA	2.5 VA
Maximum Power Consumption (DC)	2W	2W	2W
<b>Output Characteristics</b>			
Contact Configuration	DPDT	SPDT	DPDT
Output Current Rating	12 A	12 A	12 A
Contact Material	Silver Alloy	Silver Alloy	Silver Alloy
Switching Capabilities	12 A, 240 Vac, 50/60 Hz, 30 Vdc 1/3 HP @ 120 Vac 1/2 HP @ 240 Vac Pilot Duty B300	12 A, 240 Vac, 50/60 Hz, 30 Vdc 1/3 HP @ 120 Vac 1/2 HP @ 240 Vac Pilot Duty B300	12 A, 240 Vac, 50/60 Hz, 30 Vdc 1/3 HP @ 120 Vac 1/2 HP @ 240 Vac Pilot Duty B300
Minimum Switching Requirement	100 mA	100 mA	100 mA
<b>Timing Characteristics</b>			
Functions Available (1)	A,B,C,D,E,F,G,H,I,J	A,B,C,D,E,F,G,H,I,J	A,B,C
Time Scales	7	7	7
Time Ranges	0 to 999 by 0.1 sec 0 to 999 by sec 0 to 999 by 0.1 min 0 to 999 by min 0 to 999 by 0.1 hr 0 to 999 by hr 0 to 999 by 10 hr	0 to 999 by 0.1 sec 0 to 999 by sec 0 to 999 by 0.1 min 0 to 999 by min 0 to 999 by 0.1 hr 0 to 999 by hr 0 to 999 by 10 hr	0 to 999 by 0.1 sec 0 to 999 by sec 0 to 999 by 0.1 min 0 to 999 by min 0 to 999 by 0.1 hr 0 to 999 by hr 0 to 999 by 10 hr
Repeatability of the time delay @ constant voltage and temperature	0.1%	0.1%	0.1%
Reset Time	150 ms	150 ms	150 ms
Operate Time (3)	25 ms maximum	25 ms maximum	25 ms maximum
Release Time (3)	25 ms maximum	25 ms maximum	25 ms maximum
<b>General Characteristics</b>			
Electrical Life (operations at rated current) (2)	100,000 operations	100,000 operations	100,000 operations
Mechanical Life (Unpowered) (2)	10,000,000 operations	10,000,000 operations	10,000,000 operations
Dielectric Strength (Input to Contacts)	2500 Vrms	2500 Vrms	2500 Vrms
Storage Temperature Range	-30°C (-22°F) to +70°C (+158°F)	-30°C (-22°F) to +70°C (+158°F)	-30°C (-22°F) to +70°C (+158°F)
Operating Temperature Range	-20°C (-4°F) to +60°C (+140°F)	-20°C (-4°F) to +60°C (+140°F)	-20°C (-4°F) to +60°C (+140°F)
Weight	133 g (4.69 oz)	133 g (4.69 oz)	133 g (4.69 oz)
Input Indication	Green LED	Green LED	Green LED
Output Indication (Blinks = Timing or On = Energized)	RED LED	RED LED	RED LED
Enclosure Rating (according to IEC 60529 IP rating)	IP40	IP40	IP40
Approvals	cURus (File No. E43641), CE 61810-1, RoHS, cULus (UL Listed [File No. E43641] when used with Magnecraft socket 70-465)	cURus (File No. E43641), CE 61810-1, RoHS, cULus (UL Listed [File No. E43641] when used with Magnecraft socket 70-464)	cURus (File No. E43641), CE 61810-1, RoHS, cULus (UL Listed [File No. E43641] when used with Magnecraft socket 70-464)

(1) For function descriptions, see pages 33 and 34.

(2) Actual product life will vary based on electrical load, duty cycle, application, and environmental conditions.

(3) After the time delay period expires or upon trigger signal application (depends on selected function).

# Magnecraft™ Time Delay and Sensor Relays

TDRPRO Series  
SPDT, 12 A; DPDT, 12 A

## Dimensions — inches (millimeters)

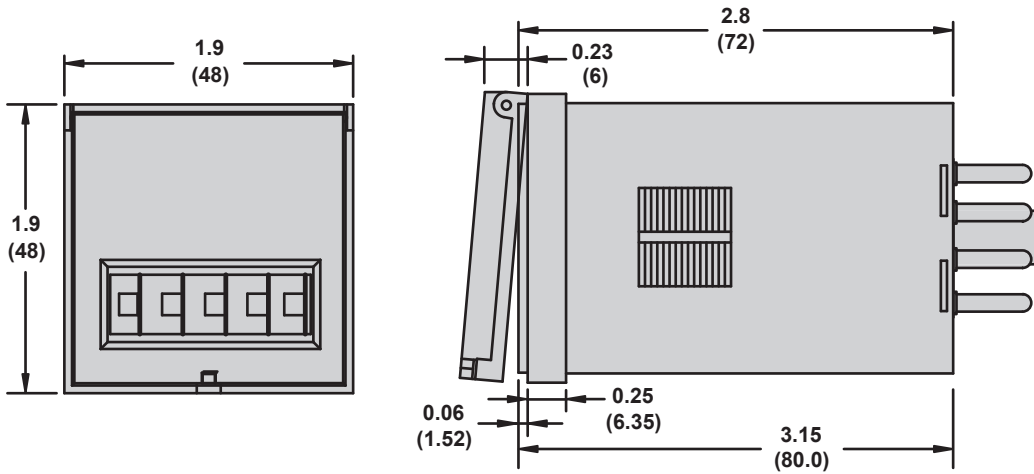

## Wiring Diagrams

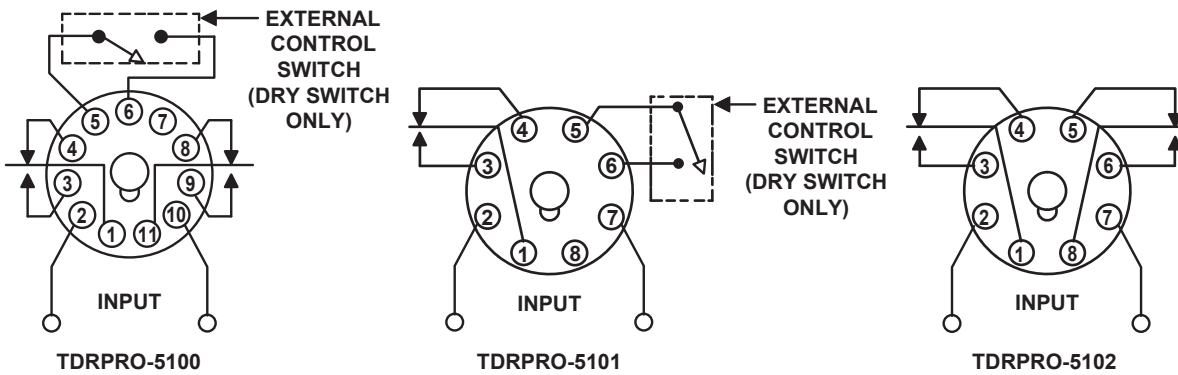



## Description

# Magnecraft™ Time Delay and Sensor Relays

## TDRSOX/SRX Series

### DPDT, 12 A

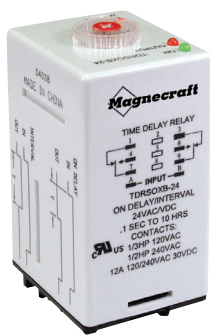

TDRSOXB Relay

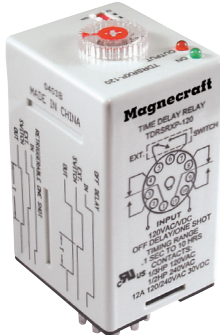

TDRSRXP Relay

## Description

Time delay relays that are dual-function, dual-voltage and socket-compatible. The integrated DIP switching allows the user to easily adjust a wide timing range. Octal and square base available.

Feature	Benefit
Integrated DIP switch	Simplifies the programming of the functions and timing
Output and input indication	Red and green LED for status check
Removable knob	Tamper resistance
Optional side and top flange mounting	Flexibility in mounting techniques
Socket compatible	Makes for easy installation and replacement

Input Voltage	Functions Available (1)	Timing Range	Contact Configuration	Rated Current (A)	Base Type	Standard Part Number
120 Vac/Vdc	A, C	100 ms to 10 hrs	DPDT	12	8 Blade Square Base	TDRSOXB-120V
12 Vac/Vdc	A, C	100 ms to 10 hrs	DPDT	12	8 Blade Square Base	TDRSOXB-12V
24 Vac/Vdc	A, C	100 ms to 10 hrs	DPDT	12	8 Blade Square Base	TDRSOXB-24V
240 Vac	A, C	100 ms to 10 hrs	DPDT	12	8 Blade Square Base	TDRSOXB-240A
120 Vac/Vdc	A, C	100 ms to 10 hrs	DPDT	12	8 Pin Octal Base	TDRSOXP-120V
12 Vac/Vdc	A, C	100 ms to 10 hrs	DPDT	12	8 Pin Octal Base	TDRSOXP-12V
24 Vac/Vdc	A, C	100 ms to 10 hrs	DPDT	12	8 Pin Octal Base	TDRSOXP-24V
240 Vac	A, C	100 ms to 10 hrs	DPDT	12	8 Pin Octal Base	TDRSOXP-240A
120 Vac/Vdc	D, E	100 ms to 10 hrs	DPDT	12	11 Blade Square Base	TDRSRXB-120V
12 Vac/Vdc	D, E	100 ms to 10 hrs	DPDT	12	11 Blade Square Base	TDRSRXB-12V
24 Vac/Vdc	D, E	100 ms to 10 hrs	DPDT	12	11 Blade Square Base	TDRSRXB-24V
240 Vac	D, E	100 ms to 10 hrs	DPDT	12	11 Blade Square Base	TDRSRXB-240A
120 Vac/Vdc	D, E	100 ms to 10 hrs	DPDT	12	11 Pin Octal Base	TDRSRXP-120V
12 Vac/Vdc	D, E	100 ms to 10 hrs	DPDT	12	11 Pin Octal Base	TDRSRXP-12V
24 Vac/Vdc	D, E	100 ms to 10 hrs	DPDT	12	11 Pin Octal Base	TDRSRXP-24V
240 Vac	D, E	100 ms to 10 hrs	DPDT	12	11 Pin Octal Base	TDRSRXP-240A

(1) For function descriptions, see pages 33 and 34.

## Part Number Explanation

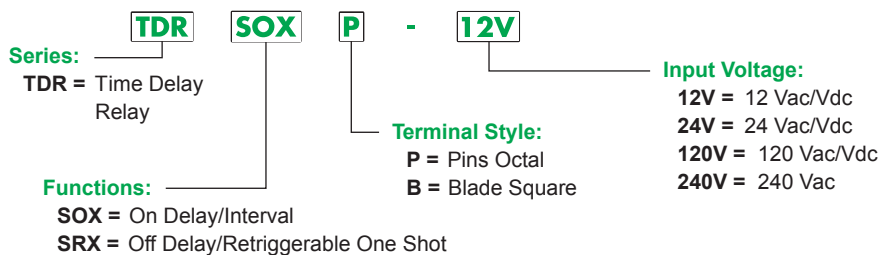

# Magnecraft™ Time Delay and Sensor Relays

## TDRSOX/SRX Series

### DPDT, 12 A

## Specifications

Part Number	TDRSOX	TDRSRX
<b>Input Characteristics</b>		
Input Voltage Range	12, 24, 120 Vac/Vdc 240 Vac	12, 24, 120 Vac/Vdc 240 Vac
Operating Voltage	80% to 110% of Nominal	80% to 110% of Nominal
Maximum Power Consumption (AC)	2.5 VA	2.5 VA
Maximum Power Consumption (DC)	2.5 W	2.5 W
<b>Output Characteristics</b>		
Contact Configuration	DPDT	DPDT
Output Current Rating	12 A	12 A
Contact Material	Silver Alloy	Silver Alloy
Switching Capabilities	240 Vac, 50/60 Hz, 30 Vdc 1/3 HP @ 120 Vac 1/2 HP @ 240 Vac Pilot Duty B300	240 Vac, 50/60 Hz, 30 Vdc 1/3 HP @ 120 Vac 1/2 HP @ 240 Vac Pilot Duty B300
Minimum Switching Requirement	100 mA at 5 Vac or Vdc	100 mA at 5 Vac or Vdc
<b>Timing Characteristics</b>		
Functions Available (1)	A,C	D,E
Time Scales	8	8
Time Ranges	0.1 sec to 1 sec 1 sec to 10 sec 10 sec to 100 sec 0.1 min to 1 min 1 min to 10 min 10 min to 100 min 0.1 hr to 1 hr 1 hr to 10 hr	0.1 sec to 1 sec 1 sec to 10 sec 10 sec to 100 sec 0.1 min to 1 min 1 min to 10 min 10 min to 100 min 0.1 hr to 1 hr 1 hr to 10 hr
Tolerance	10% of Mechanical setting	10% of Mechanical setting
Repeatability @ constant voltage and temperature	1%	1%
Reset Time	150 ms	150 ms
Trigger Pulse Length	N/A	50 ms minimum
<b>General Characteristics</b>		
Electrical Life (operations at rated current) (2)	100,000 operations	100,000 operations
Mechanical Life (Unpowered) (2)	10,000,000 operations	10,000,000 operations
Dielectric Strength (Input to Contacts)	2500 Vrms	2500 Vrms
Storage Temperature Range	-30°C (-22°F) to +70°C (+158°F)	-30°C (-22°F) to +70°C (+158°F)
Operating Temperature Range	-20°C (-4°F) to +60°C (+140°F)	-20°C (-4°F) to +60°C (+140°F)
Weight	133 g (4.69 oz)	133 g (4.69 oz)
Input Indication	Green LED	Green LED
Output Indication	RED LED	RED LED
Enclosure Rating (according to IEC 60529 IP rating)	IP40	IP40
Approvals	cULus (UL Listed [File No. E43641] when used with Magnecraft sockets), cURus (File No. E43641), RoHS	cULus (UL Listed [File No. E43641] when used with Magnecraft sockets), cURus (File No. E43641), RoHS

(1) For function descriptions, see pages 33 and 34.

(2) Actual product life will vary based on electrical load, duty cycle, application, and environmental conditions.

# Dimensions, Wiring Diagrams, Selecting Time Range and Function

# Magnecraft™ Time Delay and Sensor Relays TDRSOX/SRX Series DPDT, 12 A

## Dimensions — inches (millimeters)

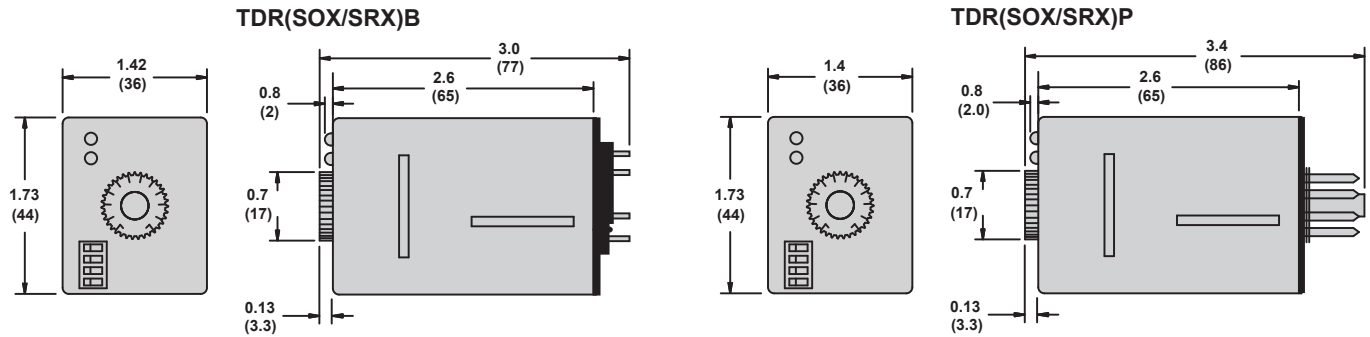

## Wiring Diagrams

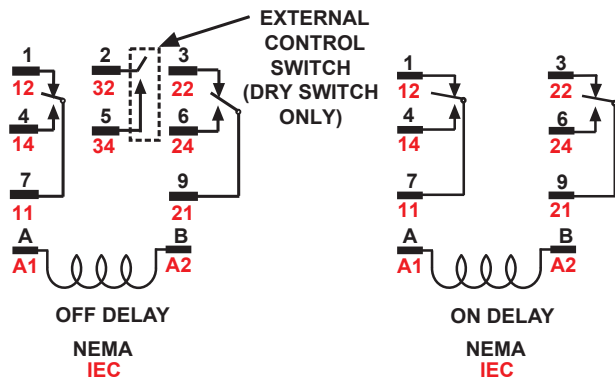

**SRXB**

**SOXB**

cULus Listed with 70-788EL11-1 or 70-463-1 sockets

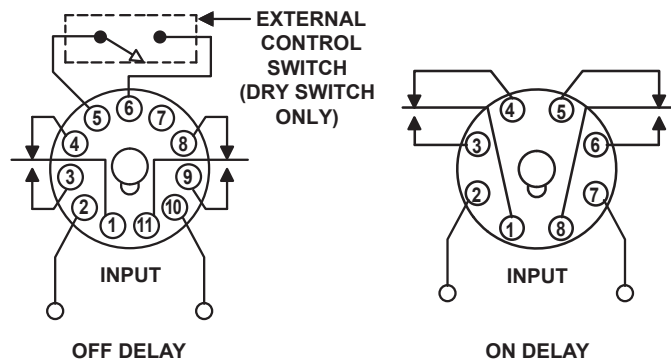

**SRXP**

**SOXP**

cULus Listed with 70-750DL11-1 or 70-750E11-1 or 70-465-1

cULus Listed with 70-750DL8-1 or 70-750E8-1 or 70-464-1

## Selecting Time Range

Time Range	Digital Switch Position		
	II	III	IV
0.1 sec – 1 sec	OFF	OFF	OFF
1 sec – 10 sec	OFF	OFF	ON
10 sec – 100 sec	OFF	ON	OFF
0.1 min – 1 min	OFF	ON	ON
1 min – 10 min	ON	OFF	OFF
10 min – 100 min	ON	OFF	ON
0.1 hr – 1 hr	ON	ON	OFF
1hr – 10 hr	ON	ON	ON

## Selecting Function (1)

Function SOX	Digital Switch Position
On Delay	OFF
Interval	ON

Function SRX	Digital Switch Position
On Delay	OFF
Interval	ON

(1) For function descriptions, see pages 33 and 34.

## Description

# Magnecraft™ Time Delay and Sensor Relays

## TDRPRO/SOX/SRX Series Accessories



### Description

The TDR accessories create a complete system solution for all your application needs. The 70-750DL socket offers an alternate installation option for plug-in models. The 16-TDRPROSC retention clip holds the relay securely in place while allowing quick and efficient installation and maintenance.

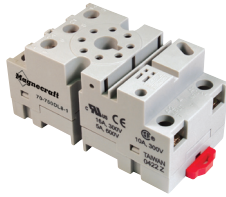

70-750DL8-1 Socket



70-750E8-1 Socket

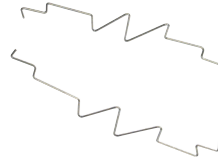

16-TDRPROSC Spring Clip



16-700DIN DIN Rail

## Relay Accessories

Description	Function	For Use With Relays	Packaging Quantities	Standard Part Number
Socket	Mounts directly to DIN Rail or Panel	TDRPRO-5101, TDRPRO-5102, TDRSOXP	10	70-750DL8-1
Socket	Mounts directly to DIN Rail or Panel	TDRPRO-5100, TDRSRXP	10	70-750DL11-1
Socket	DIN/Panel Mount with Elevator Terminals	TDRPRO-5101, TDRPRO-5102, TDRSOXP	10	70-750E8-1
Socket	DIN/Panel Mount with Elevator Terminals	TDRPRO-5100, TDRSRXP	10	70-750E11-1
Socket	DIN/Panel Mount with Screw Terminals & Clamping Plates	TDRPRO-5100, TDRSRXP	10	70-465-1
Socket	DIN/Panel Mount with Screw Terminals & Clamping Plates	TDRPRO-5101, TDRPRO-5102, TDRSOXP	10	70-464-1
Socket	Panel Mount with Screw Terminals & Clamping Plates	TDRPRO-5100, TDRSRXP	10	70-170-1
Socket	Panel Mount with Screw Terminals & Clamping Plates	TDRPRO-5101, TDRPRO-5102, TDRSOXP	10	70-169-1
Socket	DIN/Panel Mount with Screw Terminals & Clamping Plates	TDRSRXB, TDRSOXB	10	70-463-1
Metal Hold-Down Clip	Helps secure relay in socket	TDRPRO, TDRSRX	10	16-TDRPROSC
Metal Hold-Down Clip	Helps secure relay in socket	TDRSOX, TDRSRX	100	16-1344

## Socket Accessories

Description	Function	For Use With Sockets	Packaging Quantities	Standard Part Number
Metal DIN Rail	Quick installation and removal of sockets	(See table above.)	10 (1)	16-700DIN
ID Tags	Allows for identification of circuits in mult-relay applications	70-750E8-1 70-750E11-1	10	16-750/782FT-1

(1) Length is 39.3 inches.

# Magnecraft™ Time Delay and Sensor Relays

## TDRPRO/SOX/SRX Series Accessories

### Specifications

Part Number	70-750DL8-1	70-750DL11-1	70-750E8-1	70-750E11-1
Contact Configuration	DPDT	3PDT	DPDT	3PDT
Number of Terminals	8	11	8	11
Mounting Style	Panel / DIN rail	Panel / DIN rail	Panel / DIN rail	Panel / DIN rail
Current Rating	16 A	5 A	12 A	12 A
Nominal Voltage Rating	300 V	600 V	600 V	300 V
Temperature Storage Range	-40°C (-40°F) to +105°C (+221°F)	-40°C (-40°F) to +105°C (+221°F)	-40°C (-40°F) to +105°C (+221°F)	-40°C (-40°F) to +105°C (+221°F)
Protection Category according to IEC 60529 IP rating (Fingersafe™)	IP 20	IP 20	IP 20	IP 20
Internal Metal Tracks	Copper Alloy, Zinc Plated	Copper Alloy, Zinc Plated	Copper Alloy, Zinc Plated	Copper Alloy, Zinc Plated
Screw Terminals	Steel, Zinc Plated	Steel, Zinc Plated	Steel, Zinc Plated	Steel, Zinc Plated
Screw Style	Combination Head	Combination Head	Combination Head	Combination Head
Screw Size	M3.5 mm	M3.5 mm	M3.5 mm	M3.5 mm
Maximum Screw Torque	9 lb-in (1.0 N•m)	9 lb-in (1.0 N•m)	9 lb-in (1.0 N•m)	9 lb-in (1.0 N•m)
Terminal Connection	Screw Clamping	Screw Clamping	Elevator	Elevator
Terminal Layout	Logic	Logic	Non-Logic	Non-Logic
Maximum Wire Size	Solid Cu 12 / 14 (2) AWG, 4 / 2.5 (2) mm <sup>2</sup> Stranded Cu 12 / 14 (2) AWG, 4 / 2.5 (2) mm <sup>2</sup>	Solid Cu 12 / 14 (2) AWG, 4 / 2.5 (2) mm <sup>2</sup> Stranded Cu 12 / 14 (2) AWG, 4 / 2.5 (2) mm <sup>2</sup>	Solid Cu 12 / 14 (2) AWG, 4 / 2.5 (2) mm <sup>2</sup> Stranded Cu 12 / 14 (2) AWG, 4 / 2.5 (2) mm <sup>2</sup>	Solid Cu 12 / 14 (2) AWG, 4 / 2.5 (2) mm <sup>2</sup> Stranded Cu 12 / 14 (2) AWG, 4 / 2.5 (2) mm <sup>2</sup>
DIN Rail Mounting, EN 60715	35 mm (1.38 in)	35 mm (1.38 in)	35 mm (1.38 in)	35 mm (1.38 in)
Chassis Mount Screw Torque	7 lb-in (0.8 N•m)	7 lb-in (0.8 N•m)	7 lb-in (0.8 N•m)	7 lb-in (0.8 N•m)
Flammability Rating	94V-0 Class	94V-0 Class	94V-0 Class	94V-0 Class
Body Color	Light Gray	Light Gray	Light Gray	Light Gray
DIN Locking Method	Red Plastic Locking Clip	Red Plastic Locking Clip	Red Plastic Locking Clip	Red Plastic Locking Clip
Agency Approvals	cURus (File No. E70550), CSA (File No. 40787), CE 60947-1, RoHS	cURus (File No. E70550), CSA (File No. 40787), CE 60947-1, RoHS	cURus (File No. E70550), CSA (File No. 40787), CE 60947-1, RoHS	cURus (File No. E70550), CSA (File No. 40787), CE 60947-1, RoHS

Part Number	70-169-1	70-170-1	70-464-1	70-465-1
Contact Configuration	DPDT	3PDT	DPDT	3PDT
Number of Terminals	8	11	8	11
Mounting Style	Panel	Panel	Panel / DIN rail	Panel / DIN rail
Current Rating	15 A	15 A	15/10 A	15/5 A
Nominal Voltage Rating	300 V	600 V	300/600 V	300/600 V
Temperature Storage Range	-40°C (-40°F) to +105°C (+221°F)	-40°C (-40°F) to +105°C (+221°F)	-40°C (-40°F) to +105°C (+221°F)	-40°C (-40°F) to +105°C (+221°F)
Internal Metal Tracks	Copper Alloy, Zinc Plated	Copper Alloy, Zinc Plated	Copper Alloy, Zinc Plated	Copper Alloy, Zinc Plated
Screw Terminals	Steel, Zinc Plated	Steel, Zinc Plated	Steel, Zinc Plated	Steel, Zinc Plated
Screw Style	Combination Head	Combination Head	Combination Head	Combination Head
Screw Size	M3.5 mm	M3.5 mm	M3.5 mm	M3.5 mm
Maximum Screw Torque	9 lb-in (1.0 N•m)	9 lb-in (1.0 N•m)	9 lb-in (1.0 N•m)	9 lb-in (1.0 N•m)
Terminal Connection	Screw Clamping	Screw Clamping	Screw Clamping	Screw Clamping
Terminal Layout	Non-Logic	Non-Logic	Non-Logic	Non-Logic
Maximum Wire Size	Solid Cu 12 / 14 (2) AWG, 4 / 2.5 (2) mm <sup>2</sup> Stranded Cu 12 / 14 (2) AWG, 4 / 2.5 (2) mm <sup>2</sup>	Solid Cu 12 / 14 (2) AWG, 4 / 2.5 (2) mm <sup>2</sup> Stranded Cu 12 / 14 (2) AWG, 4 / 2.5 (2) mm <sup>2</sup>	Solid Cu 12 / 14 (2) AWG, 4 / 2.5 (2) mm <sup>2</sup> Stranded Cu 12 / 14 (2) AWG, 4 / 2.5 (2) mm <sup>2</sup>	Solid Cu 12 / 14 (2) AWG, 4 / 2.5 (2) mm <sup>2</sup> Stranded Cu 12 / 14 (2) AWG, 4 / 2.5 (2) mm <sup>2</sup>
DIN Rail Mounting, EN 60715	35 mm (1.38 in)	35 mm (1.38 in)	35 mm (1.38 in)	35 mm (1.38 in)
Chassis Mount Screw Torque	7 lb-in (0.8 N•m)	7 lb-in (0.8 N•m)	7 lb-in (0.8 N•m)	7 lb-in (0.8 N•m)
Flammability Rating	94V-0 Class	94V-0 Class	94V-0 Class	94V-0 Class
Body Color	Light Gray	Light Gray	Light Gray	Light Gray
DIN Locking Method	–	–	Red Plastic Locking Clip	Red Plastic Locking Clip
Product Certifications	cURus (File No. E70550), CSA (File No. 97877), CE 60947-1, RoHS	cURus (File No. E70550), CSA (File No. 97877), CE 60947-1, RoHS	cURus (File No. E70550), CSA (File No. 97877), CE 60947-1, RoHS	cURus (File No. E70550), CSA (File No. 97877), CE 60947-1, RoHS

Dimensions — inches (millimeters)

**70-750DL8-1**  
Mounts directly to DIN Rail or Panel

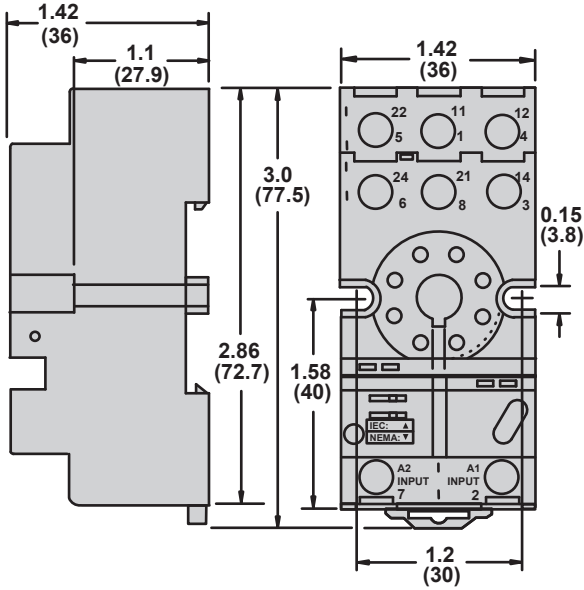

**70-750DL11-1**  
Mounts directly to DIN Rail or Panel

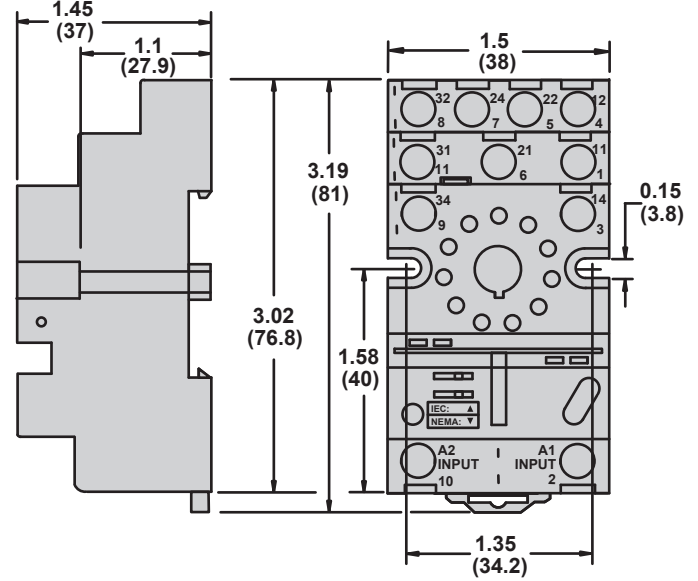

**70-750E8-1**  
DIN/Panel Mount with Elevator Terminals

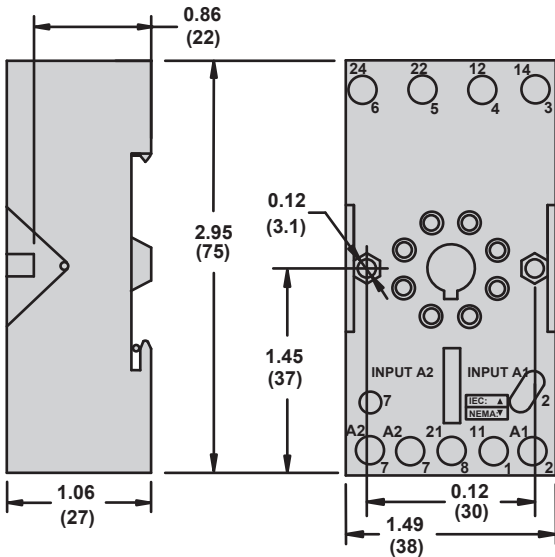

**70-750E11-1**  
DIN/Panel Mount with Elevator Terminals

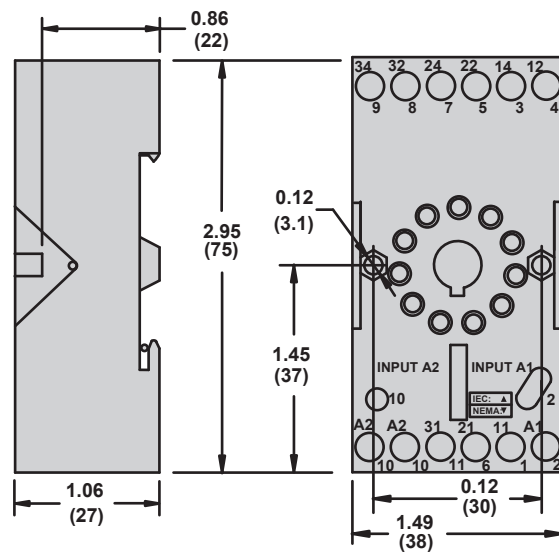

# Magnecraft™ Time Delay and Sensor Relays

TDRPRO/SOX/SRX Series Accessories

Dimensions — inches (millimeters)

**70-465-1**  
DIN/Mount with Screw Terminals & Clamping Plates

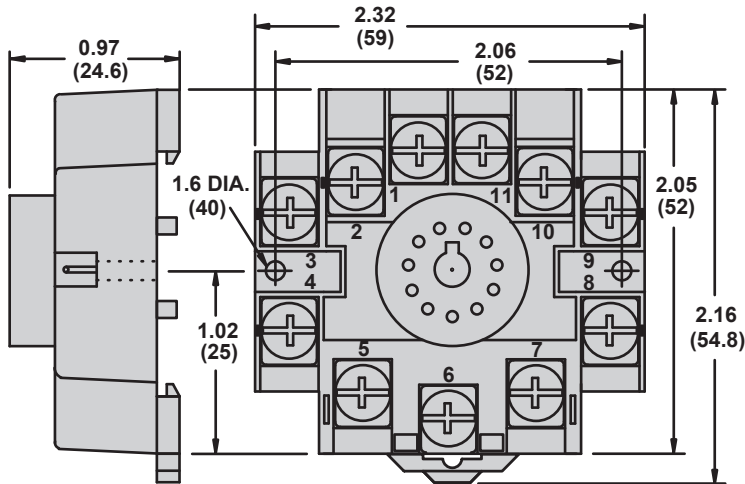

**70-170-1**  
Panel Mount with Screw Terminals & Clamping Plates

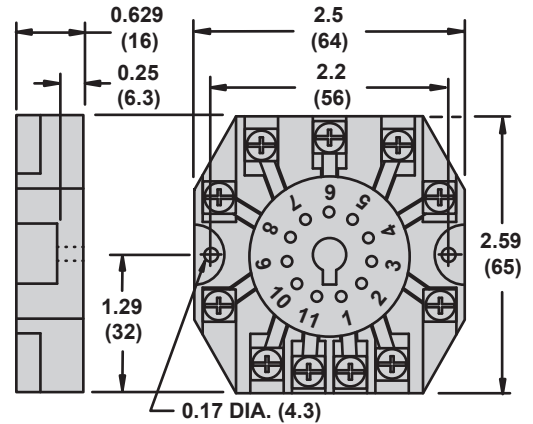

**70-464-1**  
DIN/Mount with Screw Terminals & Clamping Plates

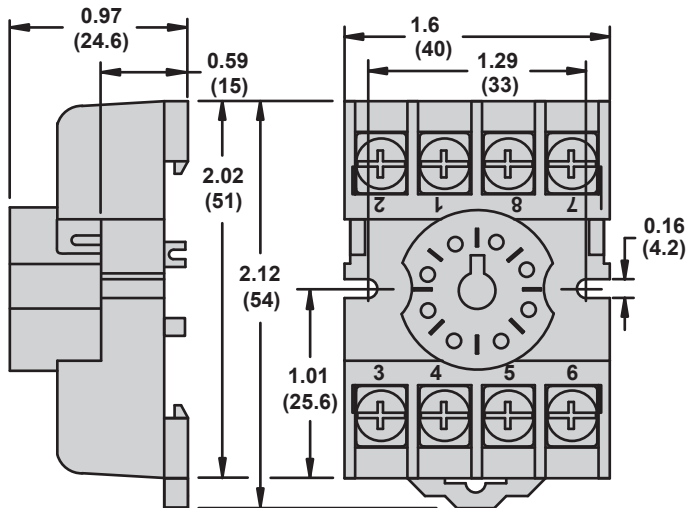

**70-169-1**  
Panel Mount with Screw Terminals & Clamping Plates

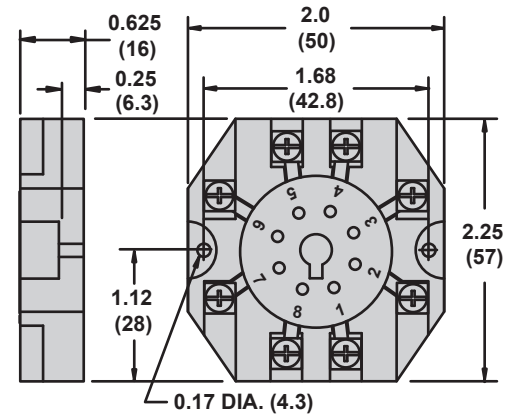

## Wiring Diagrams

70-750E8-1

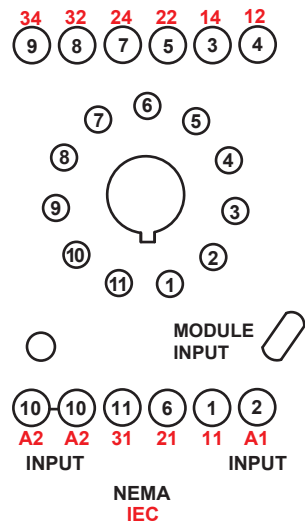

70-750E11-1

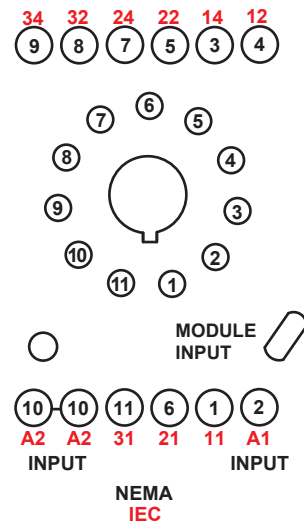

70-750DL8-1

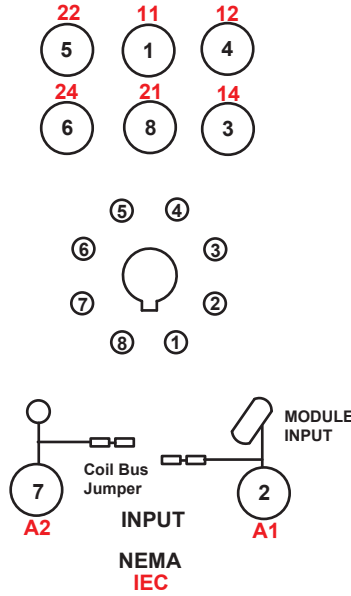

70-750DL11-1

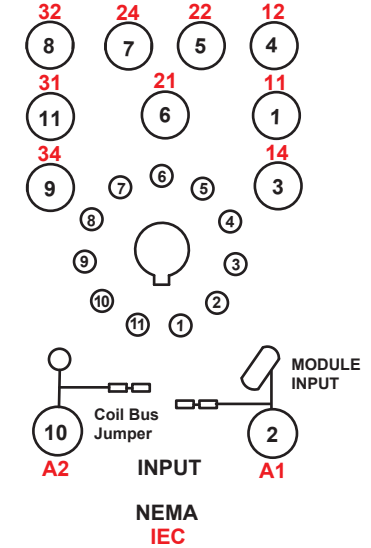

70-465-1

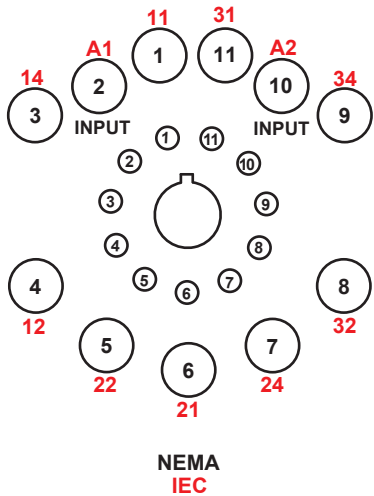

70-464-1

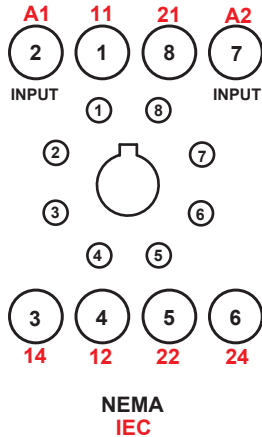

70-170-1

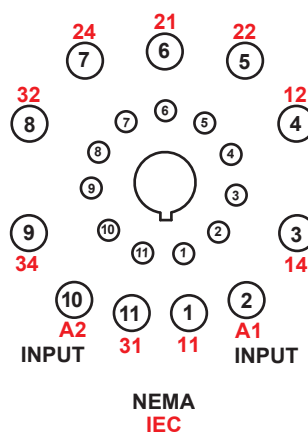

70-169-1

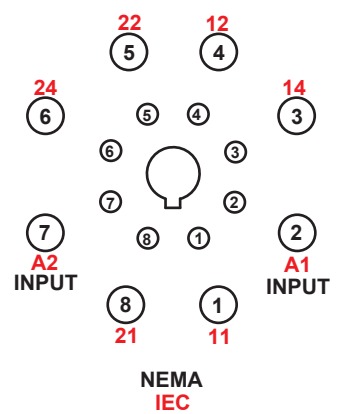



## Time Delay Relay Functions: Power Trigger

Function	Description	Timing Chart	Relays
<b>On Delay (A)</b>	<ul style="list-style-type: none"> <li>When the input voltage <b>U</b> is applied, timing delay <b>T</b> begins. Relay contacts <b>R</b> change state after time delay is complete. Contacts <b>R</b> return to their shelf state when input voltage <b>U</b> is removed. Trigger switch is not used in this function.</li> </ul>		<ul style="list-style-type: none"> <li>821, 822, TDR782,</li> <li>TDRPRO-5100,</li> <li>TDRPRO-5101,</li> <li>TDRPRO-5102,</li> <li>TDRSOX, 831, 841</li> </ul>
<b>Repeat Cycle: Starting Open (B)</b>	<ul style="list-style-type: none"> <li>When input voltage <b>U</b> is applied, time delay <b>T</b> begins. When time delay <b>T</b> is complete, relay contacts <b>R</b> change state for time delay <b>T</b>. This cycle will repeat until input voltage <b>U</b> is removed. Trigger switch is not used in this function.</li> </ul>		<ul style="list-style-type: none"> <li>821, 822,</li> <li>TDRPRO-5100,</li> <li>TDRPRO-5101,</li> <li>TDRPRO-5102,</li> <li>TDRSOX</li> </ul>
<b>Interval (C)</b>	<ul style="list-style-type: none"> <li>When input voltage <b>U</b> is applied, relay contacts <b>R</b> change state immediately and timing cycle begins. When time delay <b>T</b> is complete, contacts return to shelf state. When input voltage <b>U</b> is removed, contacts will also return to their shelf state. Trigger switch is not used in this function.</li> </ul>		<ul style="list-style-type: none"> <li>821, 822,</li> <li>TDRPRO-5100,</li> <li>TDRPRO-5101,</li> <li>TDRPRO-5102,</li> <li>TDRSOX</li> </ul>
<b>Repeat Cycle: Starting Closed (F)</b>	<ul style="list-style-type: none"> <li>When input voltage <b>U</b> is applied, relay contacts <b>R</b> change state immediately and time delay <b>T</b> begins. When time delay <b>T</b> is complete, contacts return to their shelf state for time delay <b>T</b>. This cycle will repeat until input voltage <b>U</b> is removed. Trigger switch is not used in this function.</li> </ul>		<ul style="list-style-type: none"> <li>821, 822,</li> <li>TDRPRO-5100,</li> <li>TDRPRO-5101</li> </ul>
<b>Pulse Generator (G)</b>	<ul style="list-style-type: none"> <li>Upon application of input voltage <b>U</b>, a single output pulse of 0.5 seconds is delivered to relay after time delay <b>T</b>. Power must be removed and reapplied to repeat pulse. Trigger switch is not used in this function.</li> </ul>		<ul style="list-style-type: none"> <li>821, 822,</li> <li>TDRPRO-5100,</li> <li>TDRPRO-5101</li> </ul>

### Timing Chart Key

- U** = Input voltage (Power supply)
- R** = Relay contacts
- T** = Setting time

## Time Delay Relay Functions: Switch Trigger

Function	Description	Timing Chart	Relays
<b>Off Delay (D)</b>	<ul style="list-style-type: none"> <li>Input voltage <b>U</b> must be applied continuously. When trigger switch <b>S</b> is closed, relay contacts <b>R</b> change state.</li> <li>When trigger switch <b>S</b> is opened, delay <b>T</b> begins. When delay <b>T</b> is complete, contacts <b>R</b> return to their shelf state.</li> <li>If trigger switch <b>S</b> is closed before time delay <b>T</b> is complete, then time is reset. When trigger switch <b>S</b> is opened, the delay begins again, and relay contacts <b>R</b> remain in their energized state. If input voltage <b>U</b> is removed, relay contacts <b>R</b> return to their shelf state.</li> </ul>		<ul style="list-style-type: none"> <li>821, 822,</li> <li>TDRPRO-5100,</li> <li>TDRPRO-5101,</li> <li>TDRPRO-5102,</li> <li>TDRSRX</li> </ul>
<b>Retriggerable One Shot (E)</b>	<ul style="list-style-type: none"> <li>Upon application of input voltage <b>U</b>, the relay is ready to accept trigger signal <b>S</b>. Upon application of the trigger signal <b>S</b>, the relay contacts <b>R</b> transfer and the preset time <b>T</b> begins. At the end of the preset time <b>T</b>, the relay contacts <b>R</b> return to their normal condition unless the trigger switch <b>S</b> is opened and closed prior to time out <b>T</b> (before preset time elapses). Continuous cycling of the trigger switch <b>S</b> at a rate faster than the preset time will cause the relay contacts <b>R</b> to remain closed. If input voltage <b>U</b> is removed, relay contacts <b>R</b> return to their shelf state.</li> </ul>		<ul style="list-style-type: none"> <li>821, 822,</li> <li>TDRPRO-5100,</li> <li>TDRPRO-5101,</li> <li>TDRPRO-5102,</li> <li>TDRSRX</li> </ul>
<b>One Shot (H)</b>	<ul style="list-style-type: none"> <li>Upon application of input voltage <b>U</b>, the relay is ready to accept trigger signal <b>S</b>. Upon application of the trigger signal <b>S</b>, the relay contacts <b>R</b> transfer and the preset time <b>T</b> begins. During time-out, the trigger signal <b>S</b> is ignored. The relay resets by applying the trigger switch <b>S</b> when the relay is not energized.</li> </ul>		<ul style="list-style-type: none"> <li>821, 822,</li> <li>TDRPRO-5100,</li> <li>TDRPRO-5101</li> </ul>
<b>On and Off Delay (I)</b>	<ul style="list-style-type: none"> <li>Input voltage <b>U</b> must be applied continuously. When trigger switch <b>S</b> is closed, time delay <b>T</b> begins. When time delay <b>T</b> is complete, relay contacts <b>R</b> change state and remain transferred until trigger switch <b>S</b> is opened. If input voltage <b>U</b> is removed, relay contacts <b>R</b> return to their shelf state.</li> </ul>		<ul style="list-style-type: none"> <li>821, 822,</li> <li>TDRPRO-5100,</li> <li>TDRPRO-5101</li> </ul>
<b>Memory Latch (J)</b>	<ul style="list-style-type: none"> <li>Input voltage <b>U</b> must be applied continuously. Output changes state with every trigger switch <b>S</b> closure. If input voltage <b>U</b> is removed, relay contacts <b>R</b> return to their shelf state.</li> </ul>		<ul style="list-style-type: none"> <li>821, 822,</li> <li>TDRPRO-5100,</li> <li>TDRPRO-5101</li> </ul>

### Timing Chart Key

- U** = Input voltage (Power supply)
- S** = Switch trigger (Control switch)
- R** = Relay contacts
- T** = Setting time

---

## Definition

A time delay is defined as the controlled period between the functioning of two events. A time delay relay is a combination of an electromechanical output relay and a control circuit. The control circuit is comprised of solid state components that control operation of the relay and timing range. Typical time delay functions include On-Delay, Repeat cycle (starting off), Interval, Off-Delay, Retriggerable One Shot, Repeat cycle (starting on), Pulse Generator, One Shot, On/Off Delay, and Memory Latch. Each function is explained in the tables on pages 33 and 34. Time delay relays have a broad choice of timing ranges from less than one second to many days. There are many choices of timing adjustments from calibrated external knobs, DIP switches, thumbwheel switches, or recessed potentiometer.

## Principle of Operation

Time delay relays are simply control relays with a time delay built in. Their purpose is to control an event based on time. The difference between relays and time delay relays is when the output contacts open & close: on a control relay, it happens when voltage is applied and removed from the coil; on time delay relays, the contacts will open or close before or after a pre-selected, timed interval.

Typically, time delay relays are initiated or triggered by one of two methods:

- application of input voltage (On Delay, Interval On, Flasher, Repeat Cycle, Delayed Interval & Interval/Flasher).
- opening or closing of a trigger signal (Off Delay, Single Shot & Watchdog).

These trigger signals can be one of two designs:

- a control switch (dry contact), i.e., limit switch, push button, float switch, etc.
- voltage (commonly known as a power trigger).

Definitions:

**Input Voltage:** Control voltage applied to the input terminals (see wiring diagrams below). Depending on the function, input voltage will either initiate the unit or make it ready to initiate when a trigger signal is applied.

**Trigger Signal:** On certain timing functions, a trigger signal is used to initiate the unit after input voltage has been applied. As noted above, this trigger signal can either be a control switch (dry contact switch) or a power trigger (voltage).

**Output (Load):** Every time delay relay has an internal relay (usually mechanical) with contacts that open & close to control the load. They are represented by the dotted lines in the wiring diagrams. Note that the user must provide the voltage to power the load being switched by the output contacts of the time delay relay.

# Magnecraft™ Time Delay and Sensor Relays

## Applications

Magnecraft time delay and sensor relays are designed to provide cost effective solutions for your industrial timing and sensing needs. Available in a wide array of forms, fits and functions; Magnecraft timers offer flexibility and performance for process control and industrial building applications.

### Typical Examples of Timer Applications

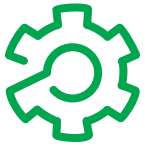

#### Automation Panels

Process controls, motor controls, emergency lighting



#### Food & Beverage

Commercial/industrial cooking equipment, filtration systems, bottling, chillers, convection ovens



#### Packaging Machinery

Conveyor motors, food processors, product/shrink wrap, solenoid controls



#### Lighting Control

Traffic signal systems, motorway information systems, theatrical lighting, ballast lighting



#### Power Supplies

Universal power supplies, battery backup systems



#### Material Handling

Motor control, conveyor controls



#### HVAC & Refrigeration

Anti-condensation equipment, compressor controls, blower controls, motorized duct/vent controls



#### Appliances

Air conditioners, water heaters, portable heaters, spa controls, water pumps

# Magnecraft™ Time Delay and Sensor Relays

The Magnecraft website ([www.serelays.com](http://www.serelays.com)) is designed to enable users to easily find the proper relay to fit design requirements and to help simplify and shorten workflow.

## Easily find the proper relay to fit design requirements

### ■ Online Catalog

Find the right product by choosing specifications, compare products side-by-side, and view technical specifications, 2D and 3D drawings, and associated accessories.

### ■ Cross Reference Search

Search our comprehensive database to identify products by manufacturer and part number, and link directly to part specifications.

### ■ 3D CAD Library

View, email, download, or insert a file directly into your open CAD software. There are 18 different file formats to choose from.

### ■ Order Free Samples

Magnecraft offers free samples as a courtesy to individuals and companies evaluating our products for their designs and applications. Sample orders are subject to approval.

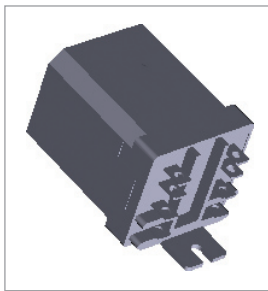

3D Models

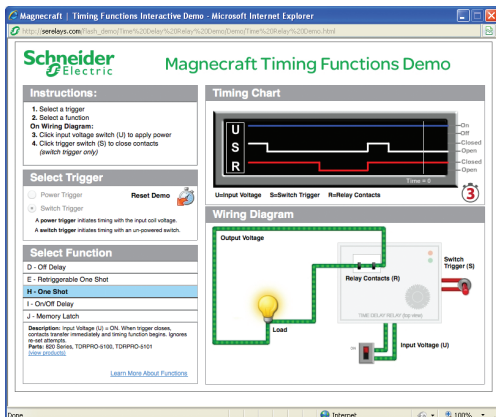

Time Delay Relay Demo

## Simplify and shorten workflow

### ■ Interactive Tools

View interactive demonstrations; such as our Time Delay Relay Interactive Demo (left) which visually demonstrates the ten different timing functions offered on Magnecraft time delay relays.

### ■ Distributor Inventory Search

Search authorized distributors' current Magnecraft inventory and buy online. (Buy online not available for all distributors).

16-700DIN	13	TDRSRXP-120V	25
	17	TDRSRXP-12V	25
	28	TDRSRXP-24V	25
16-750/782FT-1	28	TDRSRXP-240V	25
16-782FT-1	17		
16-788C1	13		
16-1344	28		
16-TDR782SC	17		
16-TDRPROSC	28		
70-169-1	28		
70-170-1	28		
70-378-1	17		
70-379-1	17		
70-461-1	17		
	28		
70-463-1	28		
70-465-1	28		
70-750DL11-1	28		
70-750DL8-1	28		
70-750E11-1	28		
70-750E8-1	28		
70-782D14-1	17		
70-782E14-1	17		
70-782EL14-1	17		
70-782EL8-1	17		
821TD10H-UNI	4		
822TD10H-UNI	4		
831VS-120A	7		
831VS-240A	7		
831VS-24D	7		
841CS1-UNI	10		
841CS2-UNI	10		
841CS5-UNI	10		
841CS8-UNI	10		
TDR782XBXA-110A	14		
TDR782XBXA-24A	14		
TDR782XBXA-24D	14		
TDR782XDXA-110A	14		
TDR782XDXA-12D	14		
TDR782XDXA-230A	14		
TDR782XDXA-24A	14		
TDR782XDXA-24D	14		
TDRPRO-5100	22		
TDRPRO-5101	22		
TDRPRO-5102	22		
TDRSOXB-120V	25		
TDRSOXB-12V	25		
TDRSOXB-24V	25		
TDRSOXB-240V	25		
TDRSOXP-120V	25		
TDRSOXP-12V	25		
TDRSOXP-24V	25		
TDRSOXP-240V	25		
TDRSRXB-120V	25		
TDRSRXB-12V	25		
TDRSRXB-24V	25		
TDRSRXB-240V	25		



**Schneider Electric USA, Inc.**

[www.serelays.com](http://www.serelays.com)

1300 S. Wolf Rd.  
Des Plaines, IL 60018  
Tel: 847-441-2540

The information and dimensions in this catalog are provided for the convenience of our customers. While this information is believed to be accurate, Schneider Electric reserves the right to make updates and changes without prior notification and assumes no liability for any errors or omissions.

Design: Schneider Electric  
Photos: Schneider Electric

© 2012 Schneider Electric. All Rights Reserved

8501CT1104R01/12  
Replaces 8501CT1104, 11/2011