

SG-24F

THREE PHASE SOLID STATE RELAY

10 THRU 25 AMPS

36 TO 440 VRMS

FEATURES

- Photo isolation
- LED status indicator
- Up to 800V blocking voltage
- Both "Zero Voltage" and phase controllable "Random" Switching versions
- High surge capability
- Built-in snubber
- Triac Output Circuitry
- UL, CUR approval pending



INPUT

Type	D38 X Z10	D38 X Z15	D38 X Z25
Control Voltage Range	3 to 32 VDC		
Turn On Voltage	3 VDC max.		
Turn Off Voltage	1 VDC min.		
Max. Input Current	35 mA at 32 VDC		
Max. Reverse Voltage	-32 VDC		

OUTPUT

Operating Voltage Range	36 to 440 Vrms		
Blocking Voltage	800 Vpk		
Type	D38 X Z10	D38 X Z15	D38 X Z25
Load Current Range (A)	0.1 to 10	0.1 to 15	0.1 to 25
Max. Surge Current (1/2 Cycle)	100 Apk	150 Apk	250 Apk
Max. Leakage Current	3 mA	5 mA	10 mA
Voltage On-state Drop (max.)	1.5 Vrms		
Max. Turn-on Time	1/2 cycle plus 1 ms		
Max. Turn-off Time	1/2 cycle plus 1 ms		
Min. Off-state Dv/Dt at Maximum Rated Voltage	200 V/us		
Min. Power Factor Allowable	0.5		

GENERAL

Dielectric Strength	4000 Vrms min. (at 50/60 Hz, 1 min.)
Insulation Resistance	1000 megohms min. (at 500 VDC)
Max. Capacitance (in/out)	8 pf
Ambient Temperature	Operating: -30°C (-22°F) to 80°C (176°F) Storage: -30°C (-22°F) to 100°C (212°F)
Mounting	Panel Mount
Termination	Screw
Weight	315 g



AMERICAN ZETTLER, INC.

www.azettler.com

75 COLUMBIA • ALISO VIEJO, CA 92656 • PHONE: (949) 831-5000 • FAX: (949) 831-8642 • E-MAIL: SALES@AZETTLER.COM

2/7/03W

SG-24F

RELAY ORDERING DATA

SG-24F	D	38	Z	25
MODEL	INPUT VOLTAGE D: 3VDC TO 32VDC	LOAD VOLTAGE 36 TO 440 VAC	ZERO CROSS FUNCTION Z: Zero cross turn-on P: Non-zero cross turn-on	LOAD CURRENT 10: 10 Amp 15: 15 Amp 25: 25 Amp

MECHANICAL DATA

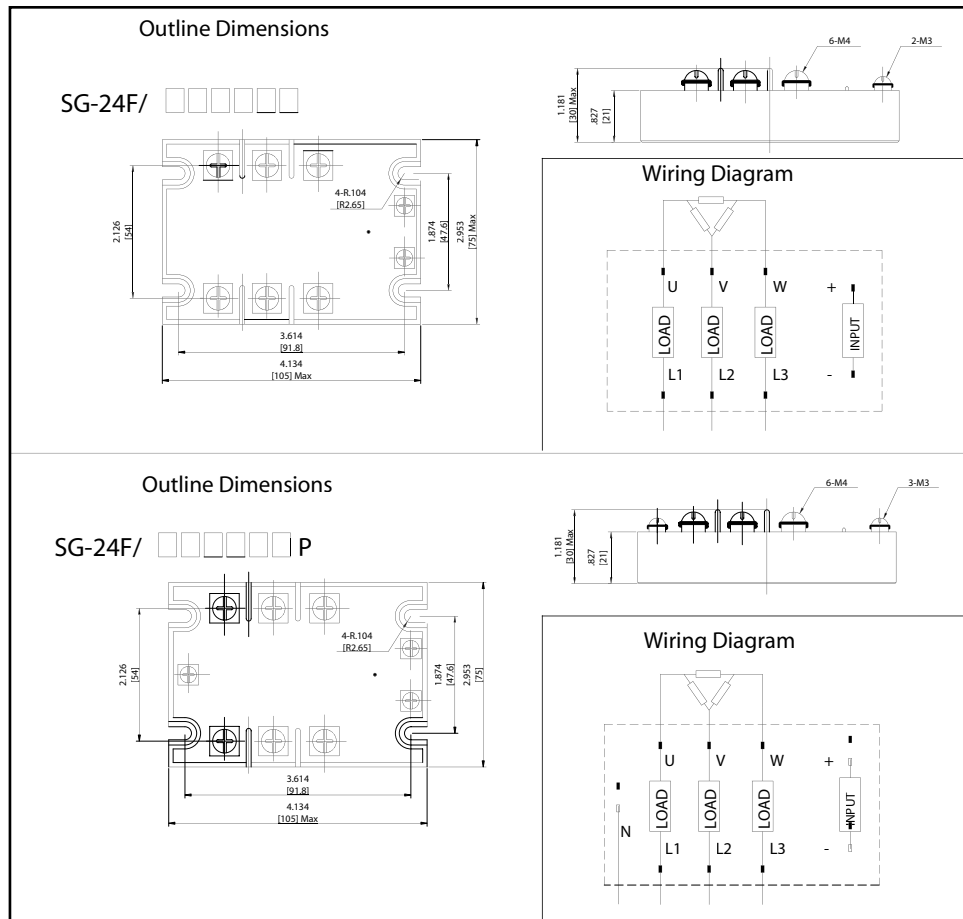

INSTALLATION

- When mounting the relays side by side, provide a space equivalent to the width of a single SSR between two adjacent SSRs. Otherwise, reduce the load current flow to 1/2 to 1/3 of the rated current.
- When mounting relays on heat sink surface, first apply a heat conductive grease to the metal back surface of the SSR. Press the SSR firmly onto the heat sink to ensure a good seal. Screw the SSR down to the heat sink.
- Next, wire the screw terminals and securely tighten the screws.

PRECAUTIONS

- Before connecting a load that generates a high surge current, such as a lamp load to the SSR, make sure that the SSR can withstand the surge current of the load.
- The product data sheet shows the non-repetitive peak value of the surge current that flows through the SSR. Normally, use 1/2 of the non-repetitive peak surge current as the standard value. If a surge current exceeding that value is expected, connect a quick-blowing fuse to protect the SSR.



AMERICAN ZETTLER, INC.

www.azettler.com

75 COLUMBIA • ALISO VIEJO, CA 92656 • PHONE: (949) 831-5000 • FAX: (949) 831-8642 • E-MAIL: SALES@AZETTLER.COM

SG-24F

HEAT SINK SF92B-150

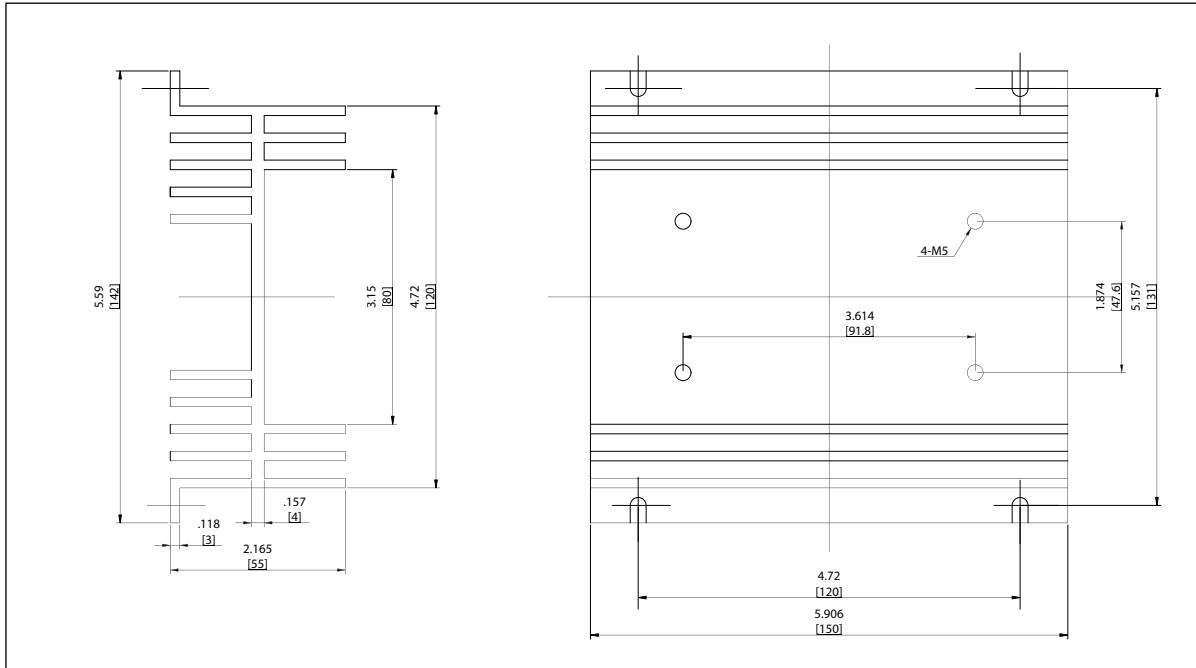

HARDWARE ORDERING DATA

DESCRIPTION	ORDER NUMBER
Heat Sink	SF92B-150

CHARACTERISTICS CURVE

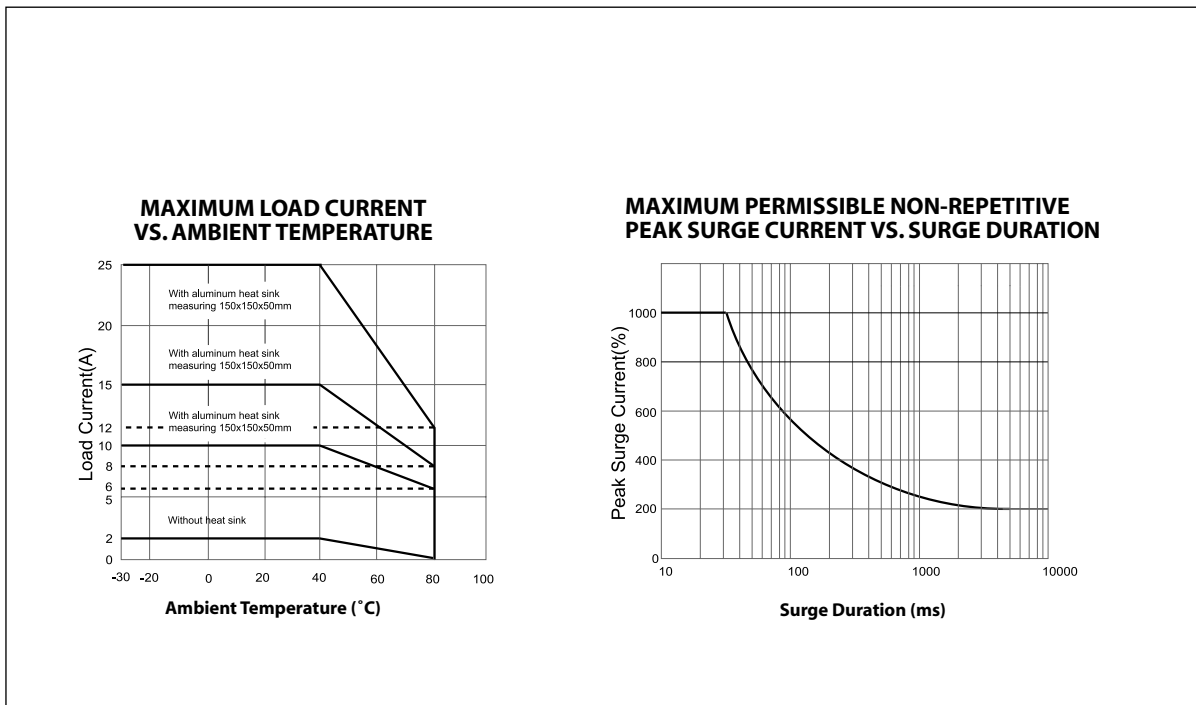

AMERICAN ZETTLER, INC.

www.azettler.com

75 COLUMBIA • ALISO VIEJO, CA 92656 • PHONE: (949) 831-5000 • FAX: (949) 831-8642 • E-MAIL: SALES@AZETTLER.COM