

## Mechanical Dimensions: Inches [mm]

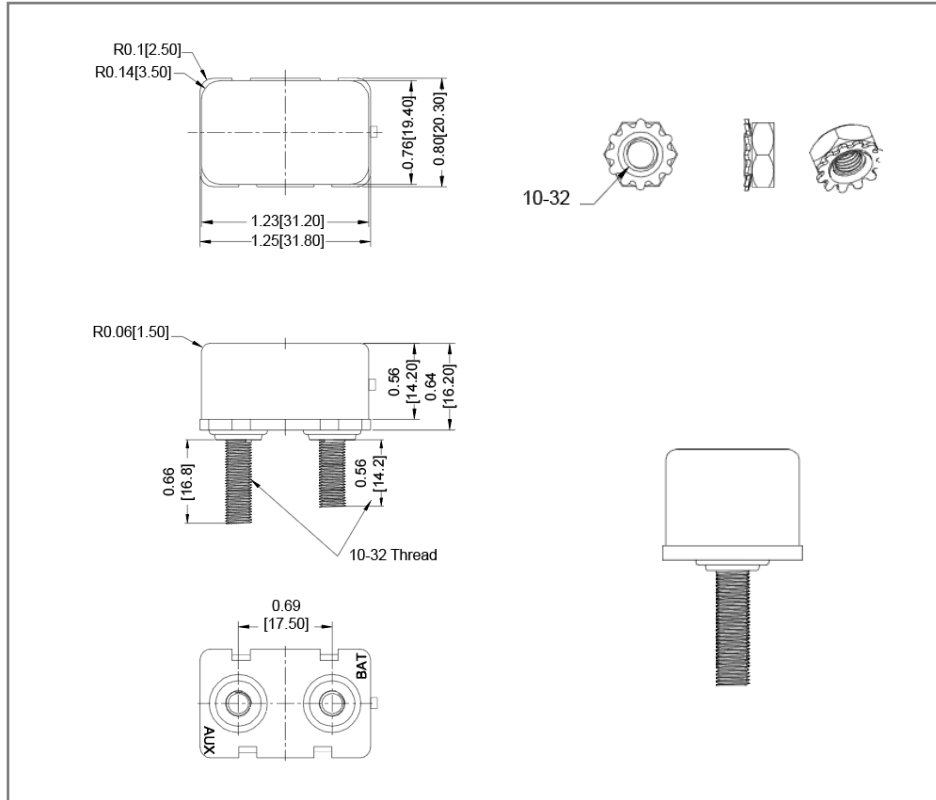

## Part Numbers Information

Optifuse P/N	Current
MRCBP-N-6A	6A
MRCBP-N-8A	8A
MRCBP-N-10A	10A
MRCBP-N-15A	15A
MRCBP-N-20A	20A
MRCBP-N-25A	25A
MRCBP-N-30A	30A
MRCBP-N-40A	40A
MRCBP-V-50A	50A

## Time vs. Percent of Rated Current

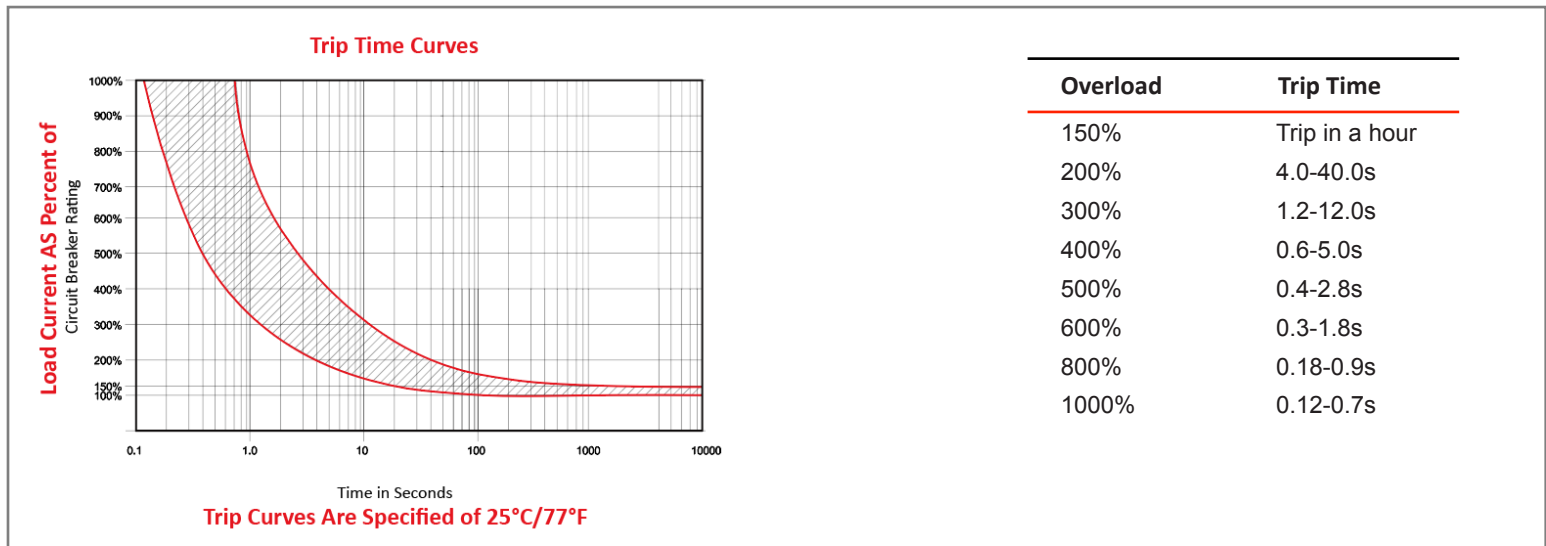

## Electrical Specifications

Voltage	32VDC
Reset Type	Type III – Manual Reset
Limited Short Circuit Current	1000A (UL1077)
Insulation Resistance	DC 500V 100M ohm 5 sec
Dielectric Strength	AC 1500V 1 minute

## Material Specifications

Body	Thermoplastic (UL94V-0)
Reset button	Thermoset
Terminals	Battery – Copper Plate (0.58”), Auxiliary – Zinc Plate (0.66”)
Mounting Type	Chassis Mount
Operation Temperature	-10°C ~ 60°C

### Ambient Temperature Correction Factor

-5 °C	(3A-4A)x 1.2, (5A-30A)x 1.12
+40 °C	(3A-4A)x 0.92, (5A-30A)x 0.94

The time/current characteristic curve depends on the ambient temperature prevailing. In order to eliminate nuisance tripping. Please multiply the current breaker current ratings by the derating factor shown below.

#### Example:

Normal Continuous Current	10A	
Ambient Temperature	40 °C	
Multiplication Factor	0.94	
Recommended Rating	$10A/0.94=10.6A$	
Select the Nearest Rating	11A	

Rev      Date of issue      Revision Notes

Designed      Approved

B	04-09-2020	Initial Drawing	RC	OF
---	------------	-----------------	----	----