

Mechanical Dimensions: Inches [mm]

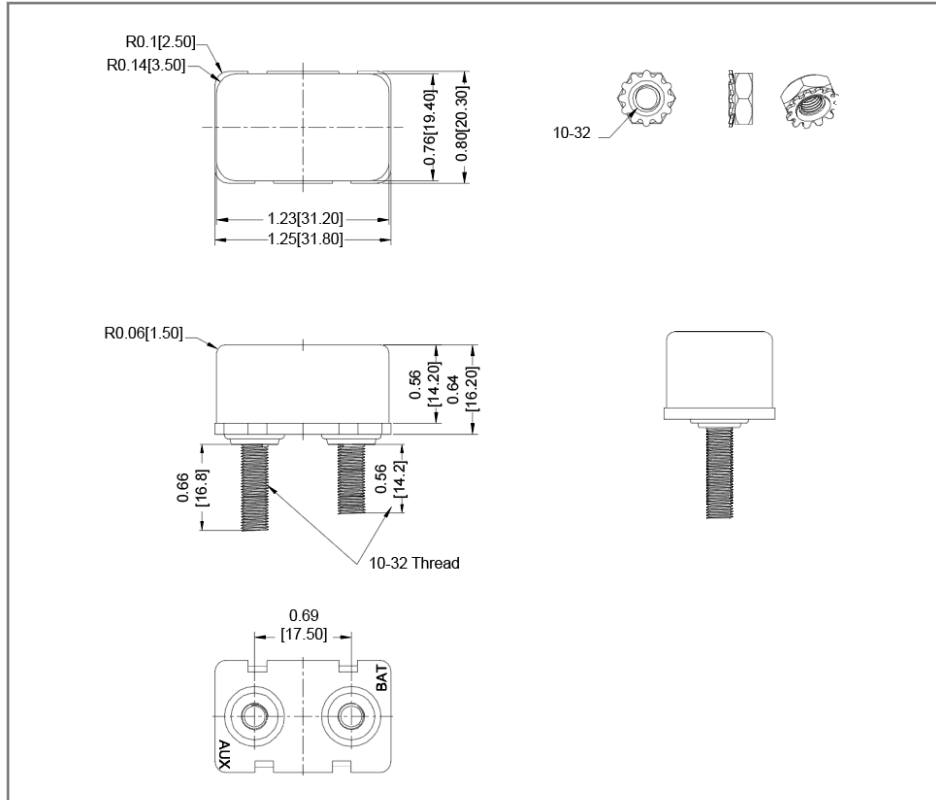

Part Numbers Information

Optifuse P/N	Current	Body Color
ACBP-N-10C	10A	Gray
ACBP-N-15C	15A	Blue
ACBP-N-20C	20A	Yellow
ACBP-N-25C	25A	White
ACBP-N-30C	30A	Green
ACBP-N-40C	40A	Orange
ACBP-N-50C	50A	Red

Time vs. Percent of Rated Current

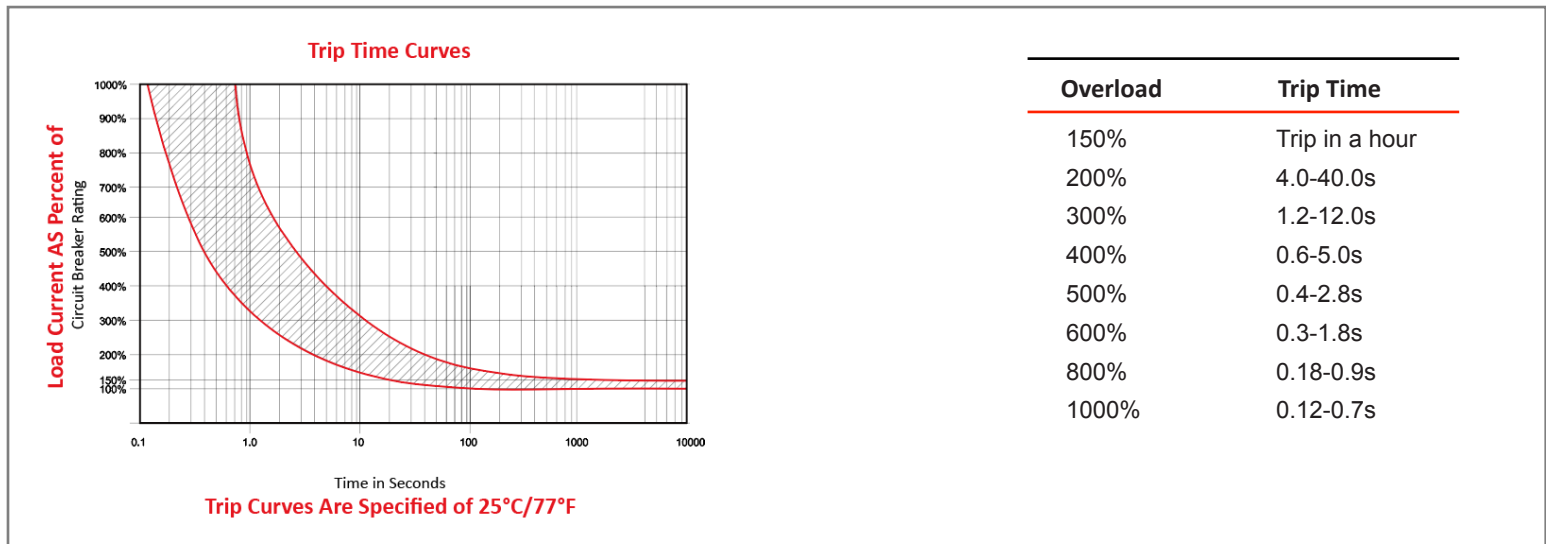

Electrical Specifications

Voltage	32VDC	PENDING
Reset Type	Type I - Auto Reset	
Limited Short Circuit Current	1000A (UL1077)	
Insulation Resistance	DC 500V 100M ohm 5 sec	
Dielectric Strength	AC 1500V 1 minute	

Material Specifications

Body	Thermoplastic (UL94V-0)
Terminals	Battery – Copper Plate (0.58”), Auxiliary – Zinc Plate (0.66”)
Mounting Type	Chassis Mount
Operation Temperature	-10°C ~ 60°C

Ambient Temperature Correction Factor

-5 °C	(3A-4A)x 1.2, (5A-30A)x 1.12
+40 °C	(3A-4A)x 0.92, (5A-30A)x 0.94

The time/current characteristic curve depends on the ambient temperature prevailing. In order to eliminate nuisance tripping. Please multiply the current breaker current ratings by the derating factor shown below.

Example:

Normal Continuous Current	10A
Ambient Temperature	40 °C
Multiplication Factor	0.94
Recommended Rating	$10A/0.94=10.6A$
Select the Nearest Rating	11A

Rev Date of issue Revision Notes

Designed Approved

B	04-09-2020	Initial Drawing	RC	OF
---	------------	-----------------	----	----