

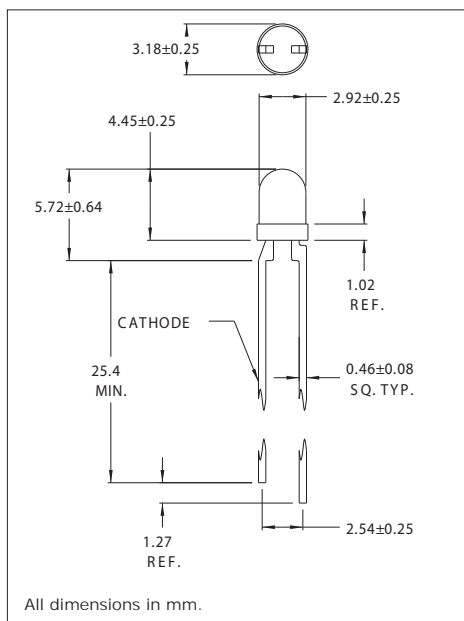

T-100 (T-1) Diffused Lens LED Lamps

DESCRIPTION AND FEATURES



These solid state indicators offer a variety of colors, wide view angles and small square leads, all contributing to their versatility as good all purpose indicator lamps. The High Efficiency Red and Yellow devices utilize GaAsP/GaP technology while the High Efficiency Green devices use an improved GaP technology. These lamps are good replacements for the Hewlett Packard HLMP-1300/1500 series.

ELECTRO-OPTICAL CHARACTERISTICS AND RATINGS

Part Number	Emitted Color	Lens Color	Package Type	Luminous Intensity		Forward Voltage		Viewing Angle (degrees)	Peak Wavelength (nm)
				Min. (mcd)	Typ. (mcd)	Typ. (V)	Max. (V)		
CMD50640	Red	Red	Diffused	0.5	1.5	1.6	2.0	60	660
CMD53640	Yellow	Yellow	Diffused	1.0	2.0	2.1	3.0	70	585
CMD53641	Yellow	Yellow	Diffused	1.5	3.0	2.1	3.0	70	585
CMD53642	Yellow	Yellow	Diffused	2.5	4.5	2.1	3.0	70	585
CMD54643	H.E.Green	Green	Diffused	2.0	5.0	2.2	3.0	75	565
CMD54644	H.E.Green	Green	Diffused	6.0	10.0	2.2	3.0	75	565
CMD57640	H.E.Red	Red	Diffused	1.0	2.0	2.0	3.0	60	635
CMD57641	H.E.Red	Red	Diffused	2.0	2.5	2.0	3.0	60	635
CMD57642	H.E.Red	Red	Diffused	3.0	4.0	2.0	3.0	60	635

ABSOLUTE MAXIMUM RATINGS

	Std. Red	All Others	Units
Power Dissipation.....	120.....	120.....	mW
Operating/Storage Temperature.....	-55 to +100.....	-55 to +100.....	°C
Peak Forward Current (1µs @ 0.3% duty cycle).....	100.....	90.....	mA
Reverse Voltage (IR=100µA).....	5.0.....	5.0.....	V
Forward Current.....	30.....	30.....	mA
Lead Solder Time at 260°C.....	5.....	5.....	seconds