

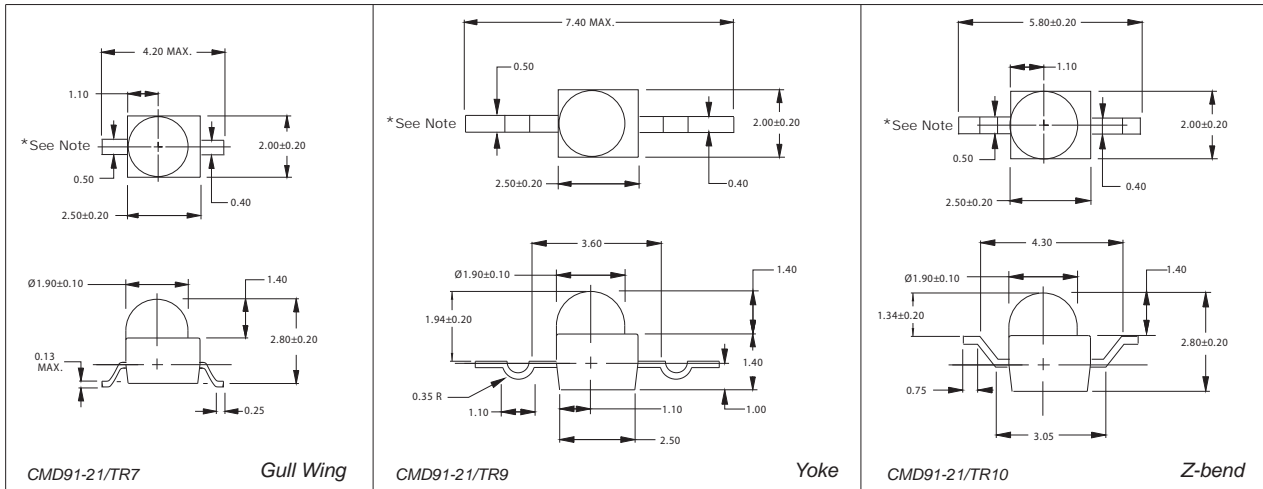

CMD91-21/TR7, TR9, TR10 Series SMT LEDs

DESCRIPTION AND FEATURES

All dimensions in mm.



Surface Mount Technology

- Tape and reel packaged for high-speed autoinsertion.
- Convection and vapor-phase reflow compatible.
- Compact form enables high density placement.

Leading Edge LED Optoelectronic Performance

- Consistent high brightness.

- Gull wing, Yoke or Z-bend lead configuration.

Exceptional Reliability

- Stringent process controls assure quality.
- Extensive qualification testing to meet strictest requirements.
- Designed to permit easy post-reflow solder joint inspection.

*Cathode for VGC/VYC/VRC
 Anode for SRC

ELECTRO-OPTICAL CHARACTERISTICS

Part Number	Emitted Color	Lens Color	Luminous Intensity		Forward Voltage		Viewing Angle (degrees)	Peak Wavelength (nm)	Package Type
			Min. (mcd)	Typ. (mcd)	Typ. (V)	Max. (V)			
CMD91-21VGC/TR7/TR9/TR10	Green	Clear	30.0	50.0	2.1	2.8	25	565	Single
CMD91-21VYC/TR7/TR9/TR10	Yellow	Clear	18.0	30.0	2.0	2.8	25	585	Single
CMD91-21VRC/TR7/TR9/TR10	H.E. Red	Clear	48.0	80.0	2.0	2.8	25	640	Single
CMD91-21SRC/TR7/TR9/TR10	Red	Clear	113.0	170.0	1.7	2.4	25	660	Single

ABSOLUTE MAXIMUM RATINGS

	Green	H.E. Red	Yellow	Red	Units
Power Dissipation.....	105	105	105	100	mW
Storage/Operating Temperature.....	-40 to +85	-40 to +85	-40 to +85	-40 to +85	°C
Peak Forward Current (1µs @ 10% duty cycle).....	150	150	150	150	mA
Reverse Voltage (IR=100µA).....	4.0	4.0	4.0	4.0	V
Lead Solder Time @ 260°C.....	5	5	5	5	Seconds
Average Forward Current.....	25	30	30	30	mA

Chicago Miniature Lamp reserves the right to make specification revisions that enhance the design and/or performance of the product