

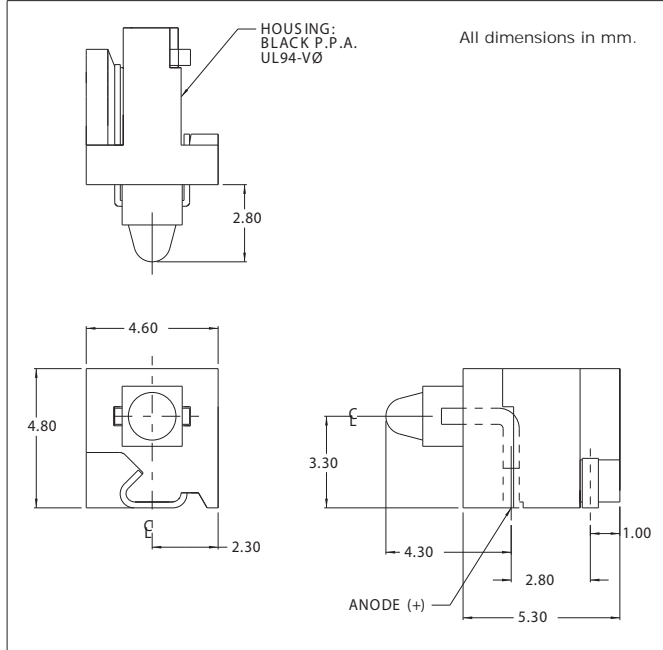

6255T Series Bright★ Angle™ Sub-Miniature SMT LED Assemblies

DESCRIPTION AND FEATURES



- Tape and reel packaged for high-speed pick-and-place installation.
- Packaged 750 pieces per reel.
- Convection and vapor-phase reflow compatible.
- Compact form enables high density placement.
- Ideal for backlighting applications.
- Wide angle viewing.
- Direct-view optics provide smooth uniform appearance.
- High output.
- Low current (2mA).
- Built-in resistor for 5V and 5V low-current.
- Perfect drop-in replacement for Dialight 591 series prism.
- 100K+ hour MTBF
- Easy post-reflow solder joint inspection.
- No adhesives.
- UL94V-0 rated housing of black polyphenylen sulfide.
- Solder pad geometry on page 1-X2.

ELECTRO-OPTICAL CHARACTERISTICS AND RATINGS

Part Number	Emitted Color	Lens Color	Luminous Intensity		Forward Voltage		Test Current (mA)	Peak Wavelength (nm)
			Typ. (mcd)	Max. (mcd)	Typ. (V)	Max. (V)		
6255T1	Red	Red	5.0	10.0	2.2	3.0	10	635
6255T3	Amber	Amber	5.0	10.0	2.0	3.0	10	603
6255T5	Green	Green	4.0	10.0	2.3	3.0	10	565
6255T7	Yellow	Yellow	3.8	10.0	2.2	3.0	10	585
6255T1-5V	Red	Red	0.5	2.0	1.8	2.2	2	635
6255T3-5V	Amber	Amber	1.2	2.0	1.8	2.2	2	565
6255T5-5V	Green	Green	0.5	2.0	1.9	2.7	2	583
6255T1LC	Red	Red	5.0	10.0	5.0	6.0	10	635
6255T5LC	Green	Green	5.0	10.0	5.0	6.0	10	565
6255T7LC	Yellow	Yellow	5.0	10.0	5.0	6.0	10	583
6255T1-5VLC	Red	Red	2.0	3.5	5.0	6.0	3.5	635
6255T3-5VLC	Amber	Amber	4.0	3.5	5.0	6.0	3.5	565
6255T7-5VLC	Green	Green	2.0	3.5	5.0	6.0	3.5	583