

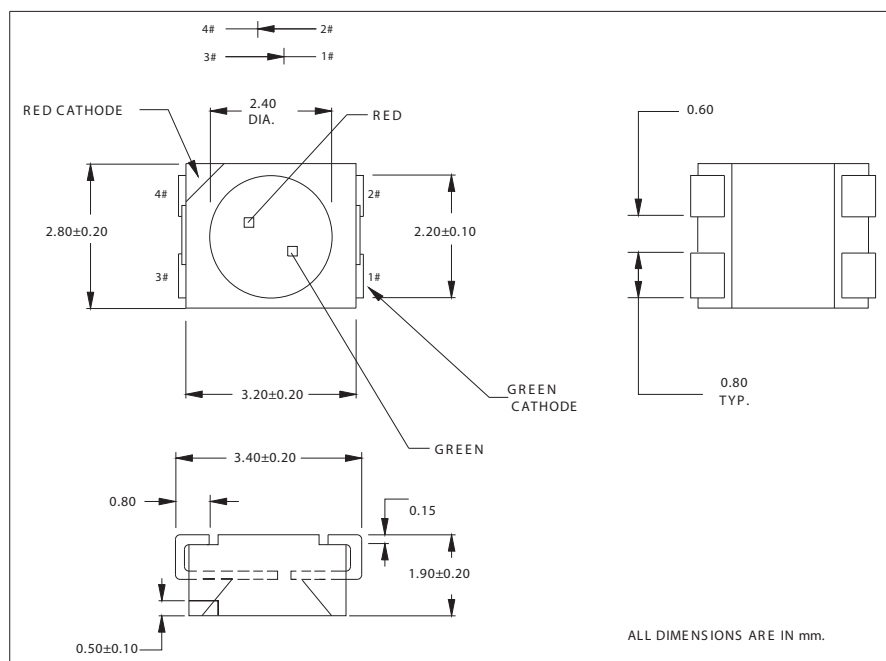

CMD67-22 SERIES SMT LEDs

DESCRIPTION AND FEATURES



Surface Mount Technology

- Tape and reel packaged for high-speed autoinsertion.
- Convection and vapor-phase reflow compatible.
- Compact form enables high density placement.
- Packaged 2000 pieces per reel.

Leading Edge LED Optoelectronic Performance

- Consistent high brightness.
- Integral lensing for narrow angle light dispersion.

Exceptional Reliability

- Stringent process controls assure quality.
- Extensive qualification testing to meet strictest requirements.
- Designed to permit easy post-reflow solder joint inspection.
- Solder pad geometry on page 1-X1.

ELECTRO-OPTICAL CHARACTERISTICS AND RATINGS

PART NUMBER	CMD67-22VRGC/TR8		CMD67-22SRUGC/TR8	
	H.E. Red	Green	Super Red	Green
Output Color	H.E. Red	Green	Super Red	Green
Package Color	Clear	Clear	Clear	Clear
Test Current (mA)	20	20	20	20
Forward Voltage Typ. (V)	2.0	2.1	1.7	2.1
Forward Voltage Max. (V)	2.8	2.8	2.4	2.8
Luminous Intensity Min. (mcd)	6.0	15.0	25.0	15.0
Luminous Intensity Typ. (mcd)	10.0	25.0	40.0	25.0
Luminous Intensity Max. (mcd)	-	-	-	-
Peak Wavelength (nm)	640	570	660	565
Viewing Angle 2θ 1/2 (degrees)	120	120	120	120
Power Dissipation (mW)	105	105	100	105
Operating Temperature (°C)	-40 to +85	-40 to +85	-40 to +85	-40 to +85
Storage Temperature (°C)	-40 to +85	-40 to +85	-40 to +85	-40 to +85
Peak Forward Current Max. (1µs @ 10% duty cycle) (mA)	150	150	150	150
Reverse Voltage (IR=100µA) (V)	5.0	5.0	5.0	5.0
Lead Solder Time @ 260°C	5	5	5	5

Chicago Miniature Lamp reserves the right to make specification revisions that enhance the design and/or performance of the product