

CMDA7 Series Right Angle Surface Mount LED

DESCRIPTION AND FEATURES

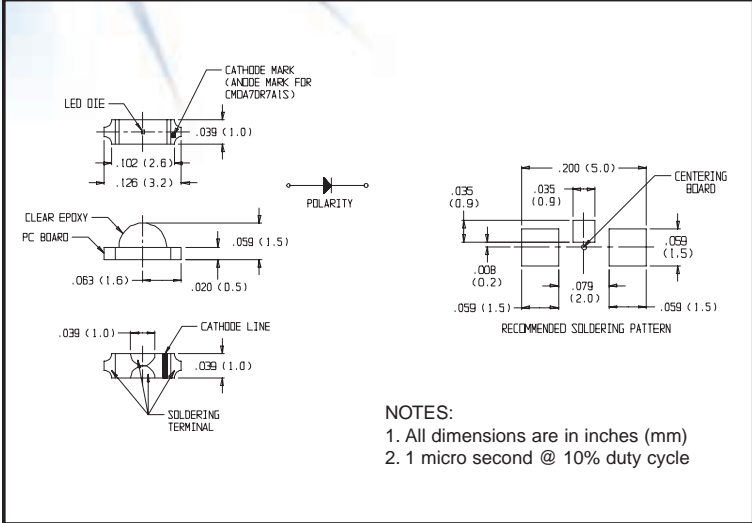

- Features**
- Small size
 - Industry standard Footprint
 - Compatible with IR solder profiles
 - Non-diffused optics
 - Right angle mount package
 - Ideal for use with Light Pipes
 - Available in 8 mm tape on 7" diameter reels
 - Packaged 3,000 pieces per reel
- Applications**
- Keypad backlighting
 - Push-button backlighting
 - LCD backlighting
 - Symbol backlighting
 - Front panel indicator

ELECTRO-OPTICAL CHARACTERISTICS AND RATINGS

Part Number	Output Color	Diffusion	Package Color	Test Current (mA)	Forward Voltage Typ. (V)	Forward Voltage Max. Typ. (V)	Luminous Intensity Min. (mcd)	Luminous Intensity Typ. (mcd)	Peak Wavelength (nm)	Viewing Angle (Degrees)
CMDA7AY7A1S	Green	Non-Diffused	Clear	20	2.2	2.6	4.0	16	570	130
CMDA7CY7A1S	Yellow	Non-Diffused	Clear	20	2.1	2.6	2.5	9	589	130
CMDA7AA7A1S	Orange	Non-Diffused	Clear	20	2.2	2.6	2.5	9	605	130
CMDA7BR7A1S	HE Red	Non-Diffused	Clear	20	2.1	2.6	2.5	11	630	130
CMDA7DR7A1S	Red	Non-Diffused	Clear	20	1.8	2.6	6.3	19	660	130

ABSOLUTE MAXIMUM RATINGS TO = 25 ° C

Part Number	Power Dissipation (mW)	Operating Temperature (°C)	Storage Temperature (°C)	Peak Forward Current Max. (See note 2) (mA)	Reverse Voltage (IR = 100 mA) (V)	Lead Solder Time at 230°C (Seconds)
AY	65	-30 to +85	-40 to +85	100	5	10
CY	65	-30 to +85	-40 to +85	100	5	10
AA	65	-30 to +85	-40 to +85	100	5	10
BR	65	-30 to +85	-40 to +85	100	5	10
DR	78	-30 to +85	-40 to +85	100	5	10

The model numbers listed above are standard off the shelf parts. For the user who may have a requirement calling for various color/electrical specifications, a part number can be determined by calling the factory.