

**CMD11-21 SMT LEDs 1206 Package Size**  
**DESCRIPTION AND FEATURES**

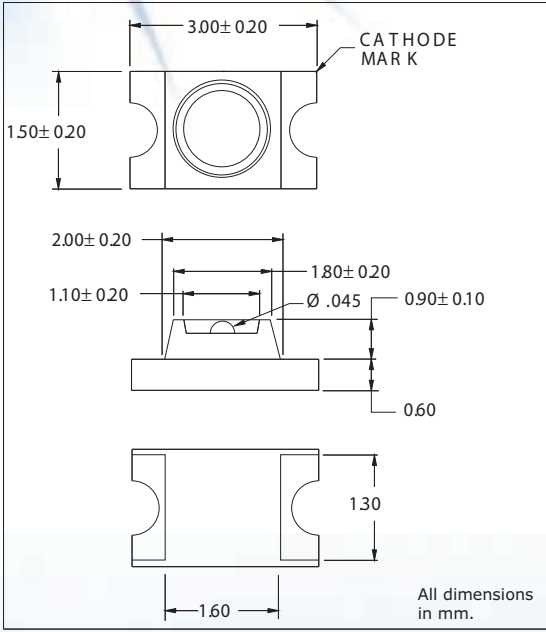

**Surface Mount Technology**

- Tape and reel packaged for high-speed autoinsertion.
- Convection and vapor-phase reflow compatible.
- Compact form enables high density placement.
- Packaged 2000 pieces per reel.

**Leading Edge LED Optoelectronic Performance**

- Consistent high brightness.
- Integral lensing for narrow angle light dispersion.
- Bi-color available.

**Exceptional Reliability**

- Stringent process controls assure quality.
  - Extensive qualification testing to meet strictest requirements.
  - Designed to permit easy post-reflow solder joint inspection.
- Solder pad geometry on page 1-X2.

**ELECTRO-OPTICAL CHARACTERISTICS AND RATINGS**

PART NUMBER	CMD11-21VGC/TR8	CMD11-21VYC/TR8	CMD11-21VRC/TR8	CMD11-21SRC/TR8	CMD11-21UYC/TR8
Output Color	Green	Yellow	Red	Red	Super Yellow
Package Type	Single	Single	Single	Single	Single
Package Color	Clear	Clear	Clear	Clear	Clear
Test Current (mA)	20	20	20	20	20
Forward Voltage Typ. (V)	2.1	2.0	2.0	1.7	2.1
Forward Voltage Max. (V)	2.8	2.8	2.8	2.4	2.8
Luminous Intensity Min. (mcd)	3.0	3.0	3.0	30.0	42.0
Luminous Intensity Typ. (mcd)	7.5	6.0	6.0	51.0	70.0
Luminous Intensity Max. (mcd)	-	-	-	-	-
Peak Wavelength (nm)	570	585	640	660	590
Viewing Angle 20 1/2 (degrees)	20	20	20	20	20
Power Dissipation (mW)	105	70	100	100	70
Operating Temperature (°C)	-30 to +90	-30 to +90	-30 to +90	-30 to +90	-30 to +90
Storage Temperature (°C)	-30 to +90	-30 to +90	-30 to +90	-30 to +90	-30 to +90
Peak Forward Current Max. (1µs@10%duty cycle) (mA)	150	150	150	150	150
Reverse Voltage (IR=100µA) (V) 5.05.05.05.0	5.0	5.0	5.0	5.0	5.0
Lead Solder Time @ 260°C	5	5	5	5	5