

# Filter Fan and Exhaust Filter

7F  
SERIES



Drying kilns



Textile machines



Machines  
for paper  
processing



Machines  
for ceramics



Wood-  
processing  
machines



Panels for  
electrical  
distribution



Control panels



Forced-air  
ventilators





**Filter Fan for electrical cabinets and enclosures  
120 V or 230 V AC versions**

- Very low acoustic noise
- Minimal depth within enclosure
- Air volume 17, 37, and 68 CFM (free flow)
- Air volume 10, 27, and 50 CFM (with Exhaust Filter installed in cabinet)
- Nominal voltage: 120 or 230 V AC (50/60 Hz)
- Time-saving installation and maintenance
- Easily replaceable filter mat
- Filter Fan supplied in reverse flow mode (7F.21)
- Black color RAL 9004 available

**NEW 7F.20.8.xxx.1020**



- Nominal voltage 120 or 230 V AC
- Air volume 17 CFM
- Rated power 17 W
- Size 1

**NEW 7F.20.8.xxx.2055**



- Nominal voltage 120 or 230 V AC
- Air volume 37 CFM
- Rated power 28 W
- Size 2

**NEW 7F.20.8.xxx.3100**



- Nominal voltage 120 or 230 V AC
- Air volume 68 CFM
- Rated power 28 W
- Size 3

For outline drawing see page 14

Fan data							
Air volume (free flow):	50 / 60 Hz CFM	14 / 17		32 / 37		59 / 68	
Air volume (with exhaust filter installed):	50 / 60 Hz CFM	8 / 10		24 / 27		44 / 50	
Noise level	dB (A)	27		42		42	
Life time at 40 °C	h	50000		50000		50000	
Electrical data							
Nominal voltage (U <sub>N</sub> )	V AC (50/60 Hz)	120	230	120	230	120	230
Operating range	AC	(0.8 ... 1.1)U <sub>N</sub>		(0.8 ... 1.1)U <sub>N</sub>		(0.8 ... 1.1)U <sub>N</sub>	
Current consumption	A	0.23	0.1	0.25	0.12	0.25	0.12
Rated power	W	17	17	28	28	28	28
Other data							
Housing, cover		Plastics according to UL94 V-0					
Filter mat (included)		G3 according to EN 779, filtering degree (80 ... 90)%					
Filter material		Synthetic fiber with progressive construction, temperature resistant to 212 °F (100 °C), self extinguishing, Class F1 (DIN 53438)					
Electrical connections		Push-in terminals					
Wire size (mm <sup>2</sup> )	min/max	0.7/2.5					
Wire size (AWG)	min/max	18/14					
Ambient temperature range		(+5 ... +131)°F (-15 ... +55)°C					
Protection category according to EN 60529		IP 54					
Protection category according to UL/NEMA		Type 12					
<b>Approvals</b> (according to type)							

**Filter Fan for electrical cabinets and enclosures  
120 V or 230 V AC versions**

- Very low acoustic noise
- Minimal depth within enclosure
- Air volume 174 and 262 CFM (free flow)
- Air volume 134 and 177 CFM (with Exhaust Filter installed in cabinet)
- Nominal voltage: 120 or 230 V AC (50/60 Hz)
- Time-saving installation and maintenance
- Easily replaceable filter mat
- Filter Fan supplied in reverse flow mode (7F.21)
- Black color RAL 9004 available

**NEW**

**7F.20.8.xxx.4250**



- Nominal voltage 120 or 230 V AC
- Air volume 174 CFM
- Rated power 45 W
- Size 4

**NEW**

**7F.20.8.xxx.4400**



- Nominal voltage 120 or 230 V AC
- Air volume 262 CFM
- Rated power 70 W
- Size 4

For outline drawing see page 15

**Fan data**

Air volume (free flow)	50 / 60 Hz	CFM	147 / 174	235 / 262
Air volume (with exhaust filter installed)	50 / 60 Hz	CFM	115 / 134	159 / 177
Noise level		dB (A)	56	72
Life time at 40 °C		h	50000	50000

**Electrical data**

Nominal voltage (U <sub>N</sub> )	V AC (50/60 Hz)	120	230	120	230
Operating range	AC	(0.8 ... 1.1)U <sub>N</sub>		(0.8 ... 1.1)U <sub>N</sub>	
Current consumption	A	0.35	0.20	0.6	0.3
Rated power	W	42	46	72	69

**Other data**

Housing, cover	Plastics according to UL94 V-0				
Filter mat (included)	G3 according to EN 779, filtering degree (80 ... 90)%				
Filter material	Synthetic fiber with progressive construction, temperature resistant to 212 °F (100 °C), self extinguishing, Class F1 (DIN 53438)				
Electrical connections	Push-in terminals				
Wire size (mm <sup>2</sup> )	min/max	0.7/2.5			
Wire size (AWG)	min/max	18/14			
Ambient temperature range	( +5 ... +131 )°F ( -15 ... +55 )°C				
Protection category according to EN 60529	IP 54				
Protection category according to UL/NEMA	Type 12				

**Approvals** (according to type)



**Filter Fan for electrical cabinets and enclosures  
120 V or 230 V AC versions**

- Very low acoustic noise
- Minimal depth within enclosure
- Air volume 294 CFM (free flow)
- Air volume 218 CFM (with Exhaust Filter installed in cabinet)
- Nominal voltage: 120 or 230 V AC (50/60 Hz)
- Time-saving installation and maintenance
- Further available versions:
  - Filter Fan supplied in reverse flow mode (7F.80)

**7F.50.8.xxx.5500**



- Nominal voltage 120 or 230 V AC
- Air volume 294 CFM
- Rated power 70 W
- Size 5

For outline drawing see page 15

Fan data			
Air volume (free flow)	50/60 Hz	CFM	294
Air volume (with exhaust filter installed)	50/60 Hz	CFM	218
Noise level		dB (A)	65
Life time at 40 °C		h	50000
Electrical data			
Nominal voltage (U <sub>N</sub> )	V AC (50/60 Hz)	120	230
Operating range	AC	(0.8 ... 1.1)U <sub>N</sub>	
Current consumption	A	0.8	0.4
Rated power	W	70	70
Other data			
Housing, cover	Plastics according to UL94 V-0, light grey (RAL 7035)		
Filter mat (included)	G3 according to EN 779, filtering degree (80 ... 90)%		
Filter material	Synthetic fiber with progressive construction, temperature resistant to 212 °F (100 °C), self extinguishing, Class F1 (DIN 53438)		
Electrical connections/wire size	screw terminals / max. 2.5 mm <sup>2</sup>		
Screw torque	Nm	0.8	
Ambient temperature range	(+14 ... +158)°F (-10 ... +70)°C		
Protection category according to EN 60529	IP 54		
Approvals (according to type)			

**Filter Fan for electrical cabinets and enclosures 24 V DC versions**

- Very low acoustic noise
- Minimal depth within enclosure
- Air volume 14, 32, and 59 CFM (free flow)
- Air volume 8, 24, and 44 CFM (with Exhaust Filter installed in cabinet)
- Nominal voltage: 24 V DC
- Time-saving installation and maintenance
- Easily replaceable filter mat
- Filter Fan supplied in reverse flow mode (7F.21)
- Black color RAL 9004 available

**NEW 7F.20.9.024.1020**



- Nominal voltage 24 V DC
- Air volume 14 CFM
- Rated power 3.6 W
- Size 1

**NEW 7F.20.9.024.2055**



- Nominal voltage 24 V DC
- Air volume 32 CFM
- Rated power 7 W
- Size 2

**NEW 7F.20.9.024.3100**



- Nominal voltage 24 V DC
- Air volume 59 CFM
- Rated power 7 W
- Size 3

For outline drawing see page 14

**Fan data**

Air volume (free flow)	CFM	14	32	59
Air volume (with exhaust filter installed)	CFM	8	24	44
Noise level	dB (A)	37.5	46	45
Life time at 40 °C	h	50000	50000	50000

**Electrical data**

Nominal voltage (U <sub>N</sub> )	V DC	24	24	24
Operating range	DC	(0.8 ... 1.1)U <sub>N</sub>	(0.8 ... 1.1)U <sub>N</sub>	(0.8 ... 1.1)U <sub>N</sub>
Current consumption	A	0.15	0.32	0.32
Rated power	W	3.6	7	7

**Other data**

Housing, cover	Plastics according to UL94 V-0		
Filter mat (included)	G3 according to EN 779, filtering degree (80 ... 90)%		
Filter material	Synthetic fiber with progressive construction, temperature resistant to 212 °F (100 °C), self extinguishing, Class F1 (DIN 53438)		
Electrical connections	Push-in terminals		
Wire size (mm <sup>2</sup> )	min/max	0.7/2.5	
Wire size (AWG)	min/max	18/14	
Ambient temperature range	( +5 ... +131)°F (-15 ... +55)°C		
Protection category according to EN 60529	IP 54		
Protection category according to UL/NEMA	Type 12		

**Approvals** (according to type)



**Filter Fan for electrical cabinets and enclosures  
24 V DC versions**

- Very low acoustic noise
- Minimal depth within enclosure
- Air volume 147 CFM (free flow)
- Air volume 115 CFM  
(with Exhaust Filter installed in cabinet)
- Nominal voltage: 24 V DC
- Time-saving installation and maintenance
- Easily replaceable filter mat
- Filter Fan supplied in reverse flow mode (7F.21)
- Black color RAL 9004 available



**7F.20.9.024.4250**



- Nominal voltage 24 V DC
- Air volume 147 CFM
- Rated power 43 W
- Size 4

For outline drawing see page 15

Fan data		
Air volume (free flow)	CFM	147
Air volume (with exhaust filter installed)	CFM	115
Noise level	dB (A)	64
Life time at 40 °C	h	50000
Electrical data		
Nominal voltage (U <sub>N</sub> )	V DC	24
Operating range	DC	(0.8 ... 1.1)U <sub>N</sub>
Current consumption	A	1.8
Rated power	W	43
Other data		
Housing, cover	Plastics according to UL94 V-0	
Filter mat (included)	G3 according to EN 779, filtering degree (80 ... 90)%	
Filter material	Synthetic fiber with progressive construction, temperature resistant to 212 °F (100 °C), self extinguishing, Class F1 (DIN 53438)	
Electrical connections	Push-in terminals	
Wire size (mm <sup>2</sup> )	min/max	0.7/2.5
Wire size (AWG)	min/max	18/14
Ambient temperature range	(+5 ... +131)°F (-15 ... +55)°C	
Protection category according to EN 60529	IP 54	
Protection category according to UL/NEMA	Type 12	
<b>Approvals</b> (according to type)		

## Ordering information

Example: Series 7F, Filter Fan for mounting in sidewalls, nominal voltage 230 V AC, size 1, air volume 14 CFM 24 m³/h.

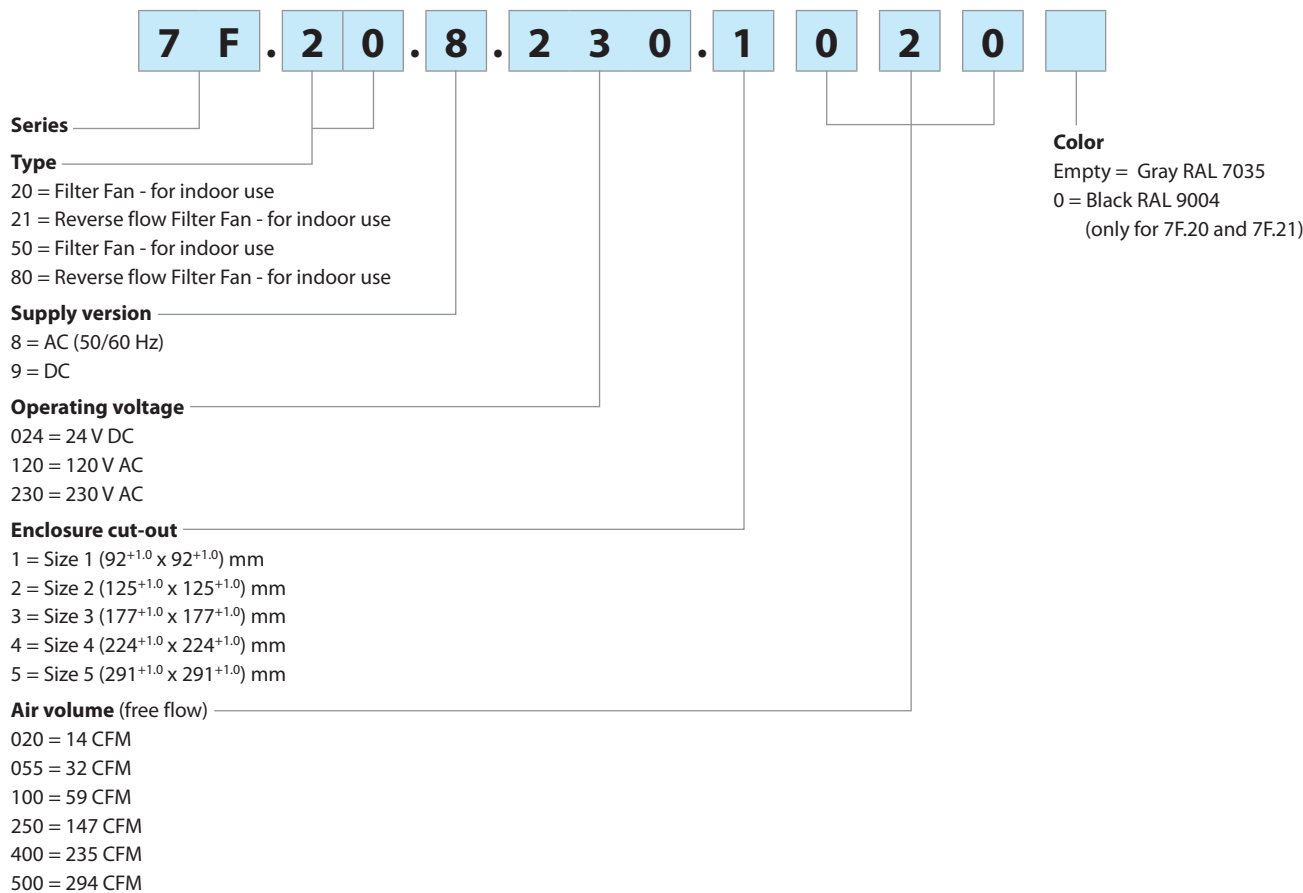

### Filter Fans - All versions

Standard versions	Reverse flow versions	
7F.20.8.120.1020	7F.21.8.120.1020	Filter Fan, Size 1
7F.20.8.120.2055	7F.21.8.120.2055	Filter Fan, Size 2
7F.20.8.120.3100	7F.21.8.120.3100	Filter Fan, Size 3
7F.20.8.120.4250	7F.21.8.120.4250	Filter Fan, Size 4
7F.20.8.120.4400	7F.21.8.120.4400	Filter Fan, Size 4
7F.50.8.120.5500	7F.80.8.120.5500	Filter Fan, Size 5
7F.20.8.230.1020	7F.21.8.230.1020	Filter Fan, Size 1
7F.20.8.230.2055	7F.21.8.230.2055	Filter Fan, Size 2
7F.20.8.230.3100	7F.21.8.230.3100	Filter Fan, Size 3
7F.20.8.230.4250	7F.21.8.230.4250	Filter Fan, Size 4
7F.20.8.230.4400	7F.21.8.230.4400	Filter Fan, Size 4
7F.50.8.230.5500	7F.80.8.230.5500	Filter Fan, Size 5
7F.20.9.024.1020	7F.21.9.024.1020	Filter Fan, Size 1
7F.20.9.024.2055	7F.21.9.024.2055	Filter Fan, Size 2
7F.20.9.024.3100	7F.21.9.024.3100	Filter Fan, Size 3
7F.20.9.024.4250	7F.21.9.024.4250	Filter Fan, Size 4

**Note:**

The technical features (air volume, dimensions and electrical parameters) for the standard Filter Fans (7F.20 and 7F.50), and the reverse flow versions (7F.21 and 7F.80) - are exactly the same.

Other versions on request.



**Exhaust Filter**

The size of the Exhaust Filter should match the size of the Filter Fan to achieve the best ventilation within the cabinet

- Minimum depth within enclosure
- Time-saving installation and maintenance
- Easily replaceable filter mat
- Black color RAL 9004 available

**NEW 7F.02.0.000.1000**



- For Filter Fans 7F.20.x.xxx.1020
- Size 1

**NEW 7F.02.0.000.2000**



- For Filter Fans 7F.20.x.xxx.2055
- Size 2

**NEW 7F.02.0.000.3000**



- For Filter Fans 7F.20.x.xxx.3100
- Size 3

For outline drawing see page 14

**Other data**

Housing, cover	Plastics according to UL94 V-0
Filter mat (included)	G3 according to EN 779, filtering degree (80 ... 90)%
Filter material	Synthetic fiber with progressive construction, temperature resistant to 212 °F {100 °C}, self extinguishing, Class F1 (DIN 53438)
Protection category according to EN 60529	IP 54
Protection category according to UL/NEMA	Type 12
<b>Approvals</b> (according to type)	

**Exhaust Filter**

The size of the Exhaust Filter should match the size of the Filter Fan to achieve the best ventilation within the cabinet

- Minimum depth within enclosure
- Time-saving installation and maintenance
- Easily replaceable filter mat (7F.02)
- Black color RAL 9004 available (only for 7F.02)

**NEW**

**7F.02.0.000.4000**



- For Filter Fans 7F.20.x.xxx.4250 or 7F.20.8.xxx.4400
- Size 4

**7F.05.0.000.5000**



- For Filter Fans 7F.50.8.xxx.5500
- Size 5

For outline drawing see page 15

**Other data**

Housing, cover	Plastics according to UL94 V-0	
Filter mat (included)	G3 according to EN 779, filtering degree (80 ... 90)%	
Filter material	Synthetic fiber with progressive construction, temperature resistant to 212 °F (100 °C), self extinguishing, Class F1 (DIN 53438)	
Protection category according to EN 60529	IP 54	
Protection category according to NEMA	UL Type 12	Type 12
<b>Approvals</b> (according to type)		

## Ordering information

Example: Series 7F, Exhaust Filter for mounting in sidewalls, size 1.

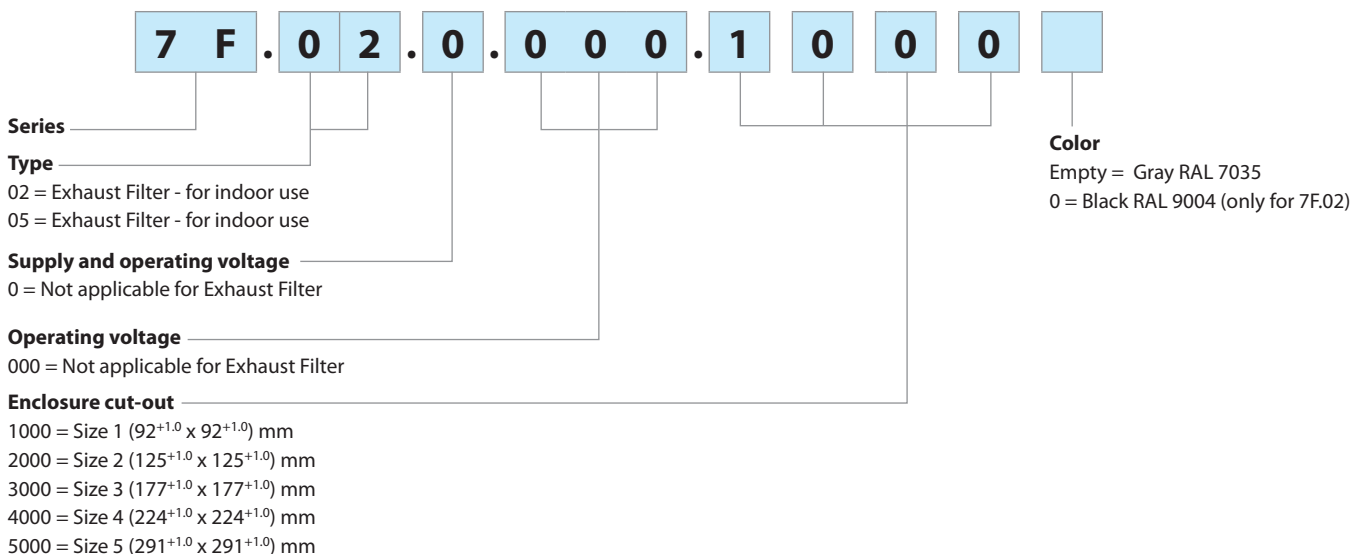

## Components

Standard-Filter Fan	Standard-Exhaust Filter	Filter mat	Size
7F.20.8.xxx.1020	7F.02.0.000.1000	07F.15	1
7F.20.8.xxx.2055	7F.02.0.000.2000	07F.25	2
7F.20.8.xxx.3100	7F.02.0.000.3000	07F.35	3
7F.20.8.xxx.4250	7F.02.0.000.4000	07F.45	4
7F.20.8.xxx.4400	7F.02.0.000.4000	07F.45	4
7F.50.8.xxx.5500	7F.05.0.000.5000	07F.55	5
7F.20.9.024.1020	7F.02.0.000.1000	07F.15	1
7F.20.9.024.2055	7F.02.0.000.2000	07F.25	2
7F.20.9.024.3100	7F.02.0.000.3000	07F.35	3
7F.20.9.024.4250	7F.02.0.000.4000	07F.45	4

Spare Filter mats	07F.15	07F.25	07F.35	07F.45	07F.55
Protection category	IP54				

## Accessories



07F.80

Pressure compensation device, for pressure compensation in closed cabinets or enclosures	07F.80
Air interface area	7 cm <sup>2</sup>
Mounting	PG 29 thread with union nut
Torque	5 (max. 10) Nm
Material	plastic according to UL94-V0
Dimensions (diameter/depth)	65.5/30.5 mm
Mounting position	upper part of cabinet sidewalls
Ambient temperature	(-49 ... +158)°F (-45 ... +70)°C
Protection category	IP 55

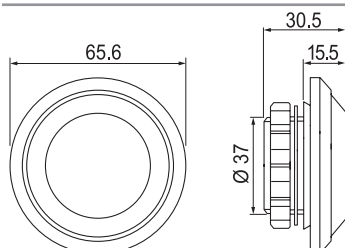

Unit package contains 2 pressure compensation devices

## Mounting instructions for Filter Fans

### Mounting arrangement of Filter Fans and Exhaust Filter

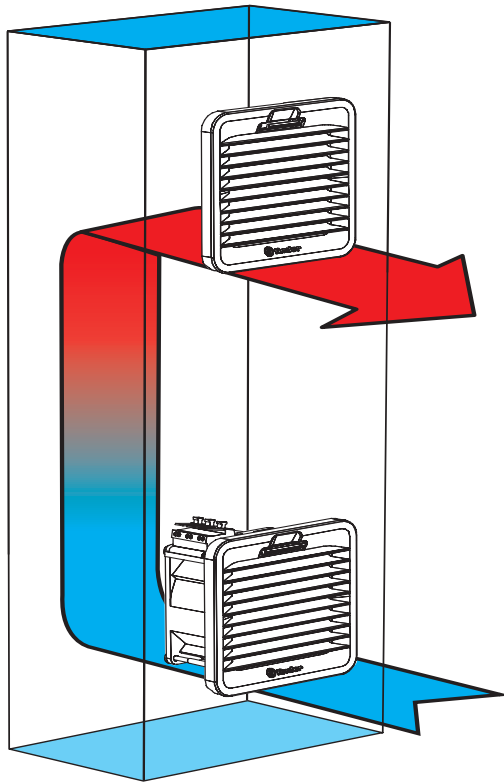

Filter

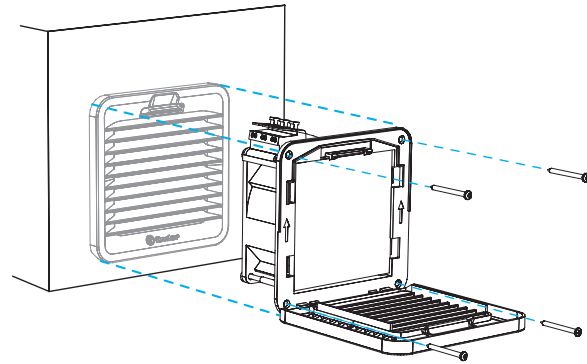

The installation with the only clips is optimized for 1.5 mm thick sheets; it is also possible with thicknesses from 1 to 2.5 mm. Fixing with screws (supplied) is recommended. Tightening torque 0.3 Nm.

Fan

## Replacement of Filter mat ( Type 7F.20)

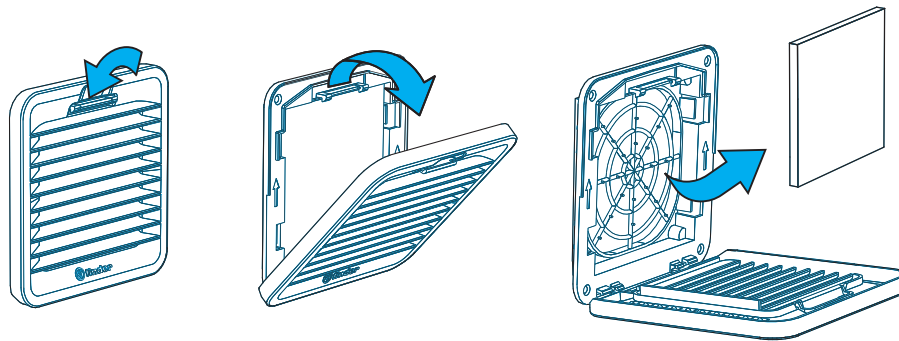

## Drilling template and mounting cut-outs for Filter Fans and Exhaust Filter

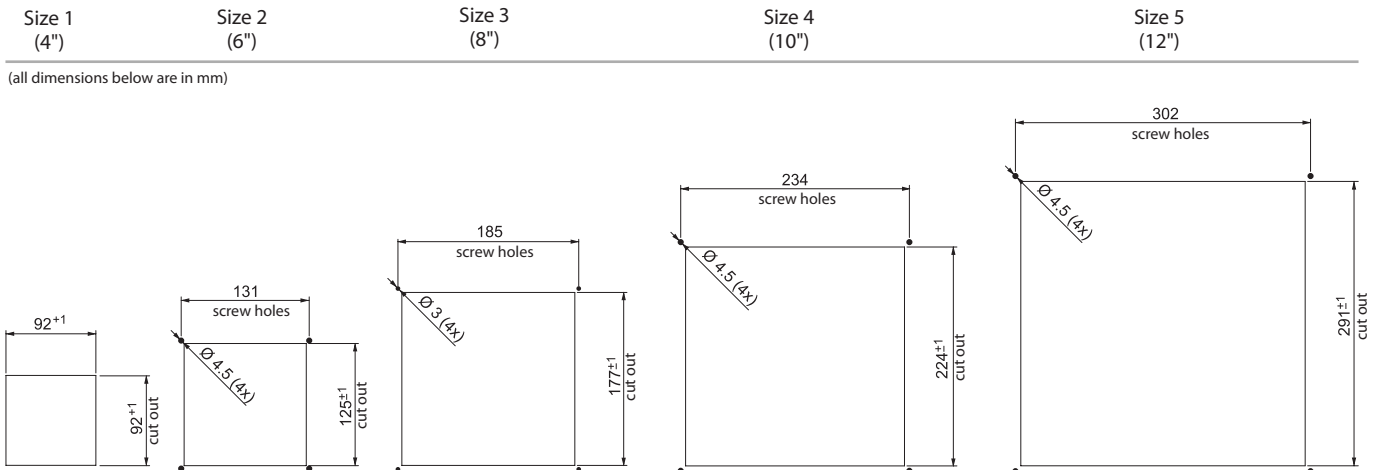

### Mounting and maintenance

1. Make the panel cut-out according to the size of the Filter Fan or Exhaust Filter in the sidewall of the cabinet as appropriate.  
A template of the panel cut-out is included in the packaging of the Filter Fan or Exhaust Filter.
2. Make the electrical connection.
3. Mount by simply snapping the side-located lugs on the Filter Fan or Exhaust Filter into the panel cut-out (without using screws for sidewall thickness of 1.2...2.4 mm).  
At other thickness it is recommended to mount the Filter Fan by the screws supplied (for size 1, the template shows the mounting cut-out only).
4. When screws are needed for the mounting, remove the plastic cover and fix the Filter Fan with the 4 screws supplied.  
Then insert the filter mat and snap the plastic cover to the mounting frame.
5. During maintenance or when replacing the filter mat remove the plastic cover, replace the filter mat and snap on the plastic cover.

**Outline drawings** (all dimensions below are in mm)

Type 7F.20.x.xxx.1020

AC version

DC version

Type 7F.02.0.000.1000

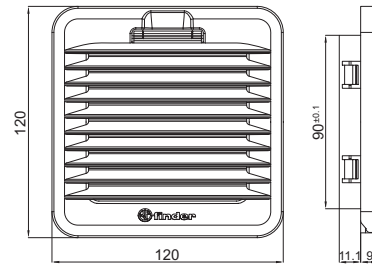
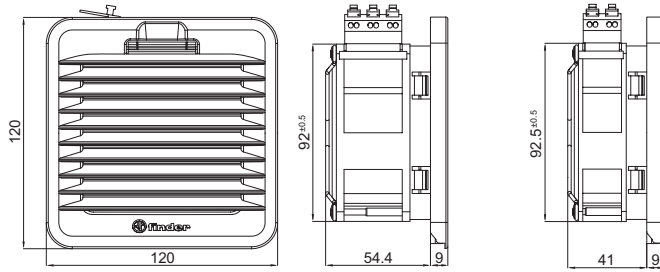

Type 7F.20.x.xxx.2055

Type 7F.02.0.000.2000

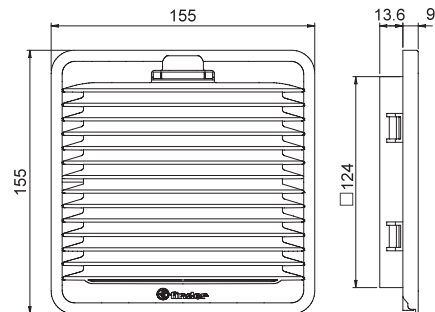
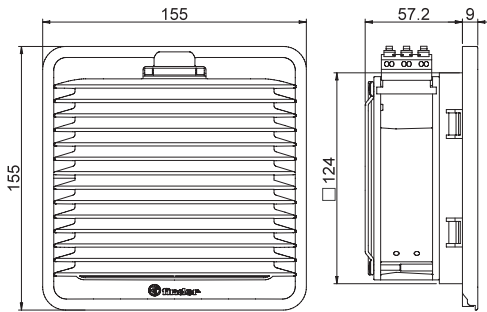

Type 7F.20.x.xxx.3100

Type 7F.02.0.000.3000

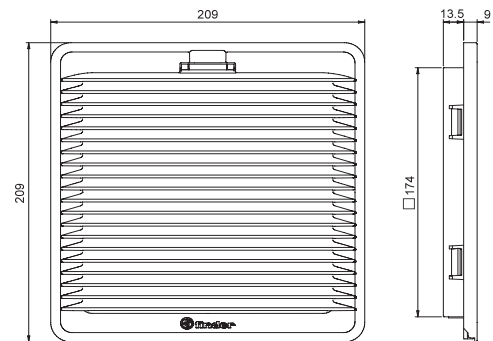
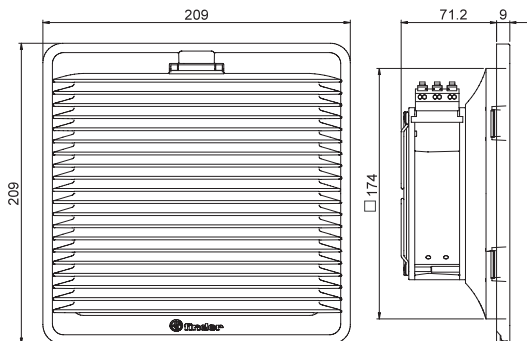

Outline drawings (all dimensions below are in mm)

Type 7F.20.x.xxx.4250

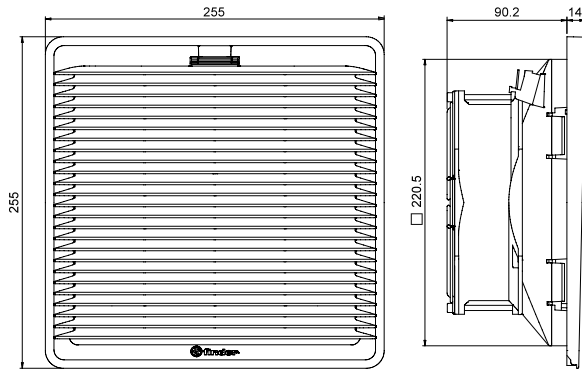

Type 7F.02.0.000.4000

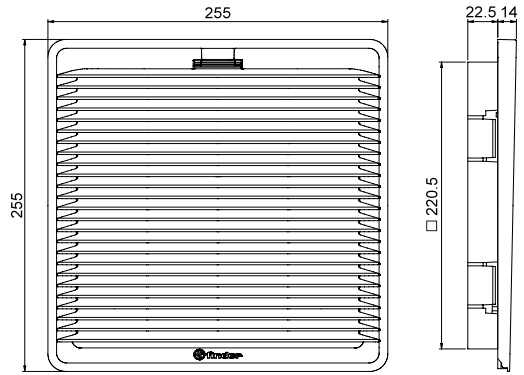

Type 7F.20.x.xxx.4400

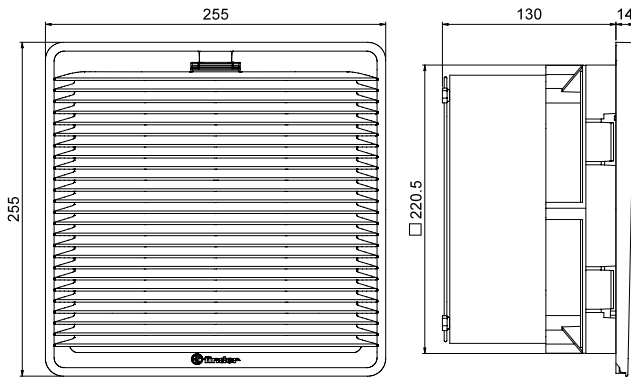

Type 7F.02.0.000.4000

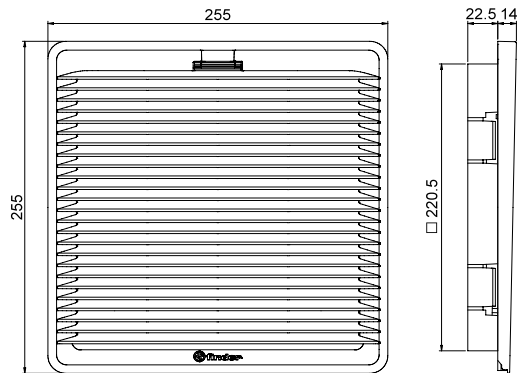

Type 7F.50.x.xxx.5500

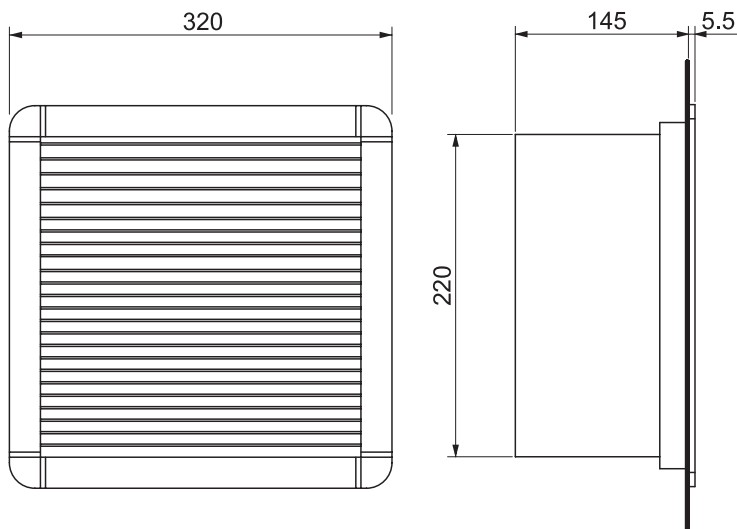

Type 7F.05.0.000.5000

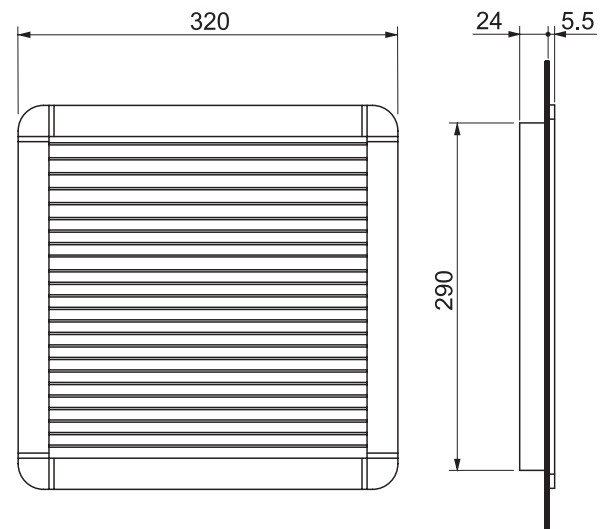

Fan selection

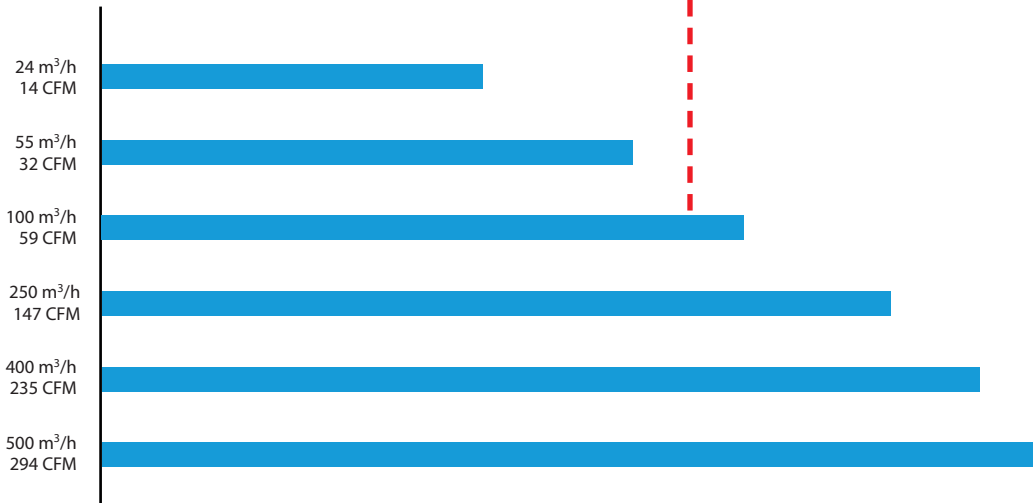
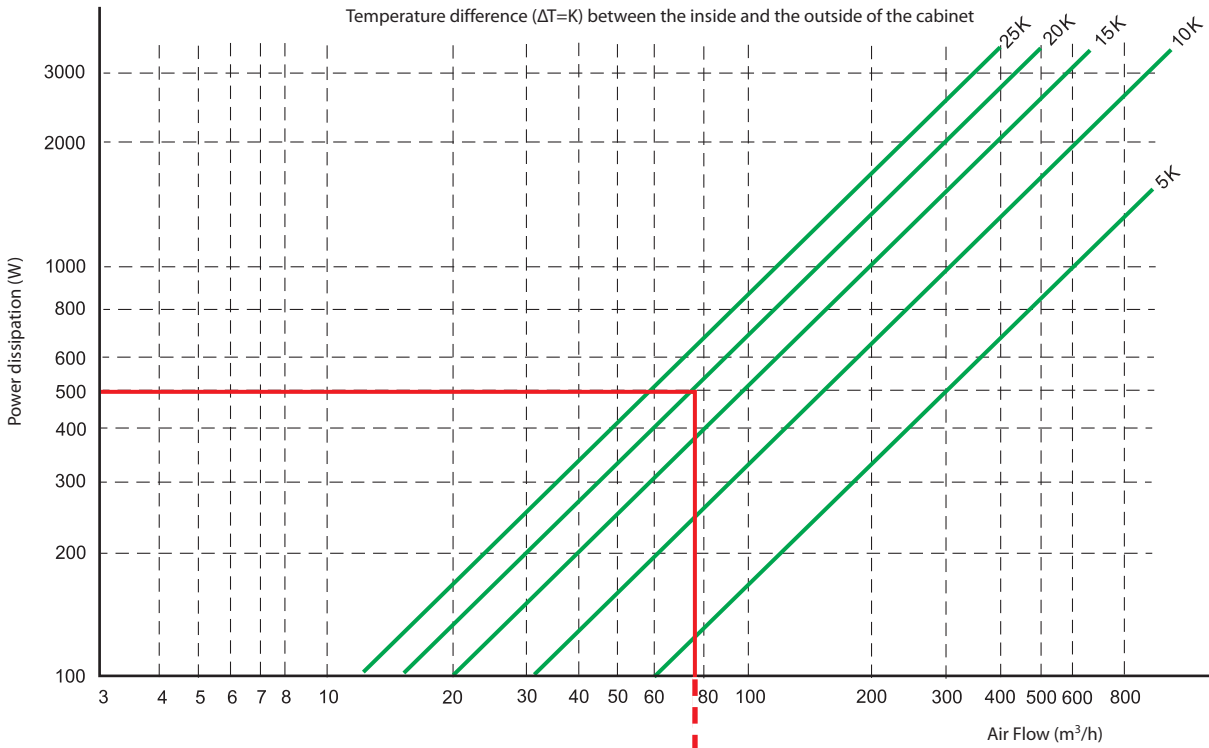

**Example**

First, estimate the power dissipated within the cabinet. Then calculate the maximum difference between the internal and external temperature (green lines) by considering the difference between the maximum permitted internal temperature (as dictated by the temperature rating of the enclosed components, or specification) and the maximum temperature expected outside the cabinet.

The projection onto the X axis, of the intersection between the power (watts) and the appropriate green line, corresponds to the air flow rate in  $m^3/h$  required to meet the maximum internal temperature limit. Extending this line vertically to intersect with the blue horizontal lines, indicates the most appropriate model of 7F fan to be fitted to the cabinet to provide the requisite air flow.

The example above considers a cabinet with an internal thermal power dissipation of 500 W, and assumes the maximum temperature difference between the inside and the outside of the cabinet to be 20K. The required air flow can be seen to be a little less than 80  $m^3/h$ .

It is suggested that this is increased by 10% to allow for the affects of a dirty filter.

And so, it can be seen that models of the 7F with 100  $m^3/h$  flow rate will provide the proper dissipation of heat under these circumstances.



## Application notes

### Filter fan

The ball-bearing axial fan housing is made of aluminium and the rotor is made of plastic or metal (depending on the type).

### Filter classes

Within EN 779 are specified 9 filter classes, categorised into 4 coarse dust filters and 5 fine dust filters.

The coarse dust filters G1 - G4 are able to filter particles > 10 µm and the fine dust filters G5 - G9 are able to filter particles from (1...10)µm.

Filter classes	Example of particle	Particle size
G1 - G4 (EU1 - EU4)	Textile fibers, hair, sand, pollen, spores, insects, cement dust	> 10 µm
G5 - G9 (EU5 - EU9)	Pollen, spores, cement dust, tobacco smoke, oil smoke, soot	(1 ... 10)µm

### Filtering degree (Am)

The degree of filtering (Am) is the percentages of dust, by weight, that is caught and retained by the filter.

### Filter mats

The quality of these filters mats has been independently tested, according EN 779 and branded after passing the test.

The filter mats are to filter class G3 and have an average filtering degree of (80...90)%.

### Filter material

The filter material consists of a synthetic fiber with progressive construction which is moisture-resistant to 100% RH and temperature resistant up to 212 °F (100 °C).

According to the strict requirements of fire class F1, DIN 53438, these filter mats are self extinguishing.

### Progressive construction at filter mats

The individual fibers of these filter mats are bonded by a special process to provide a progressive construction where the fiber size and spacing varies through the thickness of the filter mat.

This means that coarse dust particles are caught early and fine dust later through the thickness of the mat. In this way the entire depth of the filter mat is used.

### Flammability class of the housing and the cover

The plastic materials used comply with flammability class V-0, according UL94.

### Filter fan in "reverse flow" version

As supplied, the standard Filter Fan is in "draw-in"- mode, which means that cool air is filtered and drawn into the cabinet. In some cases it may be required that the warm air is blown out of the cabinet.

In which case it is possible to get Filter Fans in "Exhaust Filter" mode version (7F.21 and 7F.80).

### Mounting of the pressure compensation device

In sealed cabinets and enclosures the internal pressure can vary due to changes in temperature. The pressure compensation device (07F.80) will relieve this internal/external pressure differential whilst maintaining a high level of protection - preventing the ingress of dust and moisture into the cabinet or the enclosure. The pressure compensation device is approved for use in cabinets and enclosures according to DIN EN 62208.

Drill a hole Ø 37<sup>+1.0</sup> mm in the housing wall and fix the pressure compensation device with the accompanying nut. It is important to ensure that the sealing ring is located on the outside. To ensure optimum pressure balance, it is recommended to fit 2 pressure compensation device at the upper sides of the cabinet or enclosure.

### Fan Motor Reversal

By reversing the fan motor on certain sizes, the air direction can be changed from "Inlet" Filter Fan mode to "Outlet" Filter Fan mode.