

MODEL 442

Multi-Stage Alternator

- Replaces Mechanical Alternators
- User Selectable for:
 - Single Motor/Pump
 - Two Motor/Pump (duplex)
 - Three Motor/Pump (triplex)
 - Four Motor/Pump (quadraplex)
- Unit Remembers Which Motor/Pump Is Next During Power Loss
- Sequence-On, Simultaneous-Off Operation

DESCRIPTION

The **Model 442 Multi-Stage Alternator** is designed to control the operating sequence of multi-stage motor/pumping systems. It can also be used to maintain the desired level of pressure-on air compressor systems. Four motor select DIP switches located on the front panel allow the alternator to control a single-motor/pump, two-motor/pump, three-motor/pump or four-motor/pump system.

The Model 442 will assure that only the necessary motors/pumps are operating, and that the run time for each motor/pump is approximately equal. Motors are sequenced "Sequence-On, Simultaneous-Off". If the motor/pumping demand requires only one motor/pump at a time, the alternator will start the next motor/pump in sequence each time an input switch is closed. Input switches may be float switches, pressure switches, flow switches, etc., as required by the application.

Potential uses for the Model 442 include water supply systems, sewage disposal plant systems, storage tank filling systems, air compressor systems, irrigation and water recycling systems.

DIMENSIONS

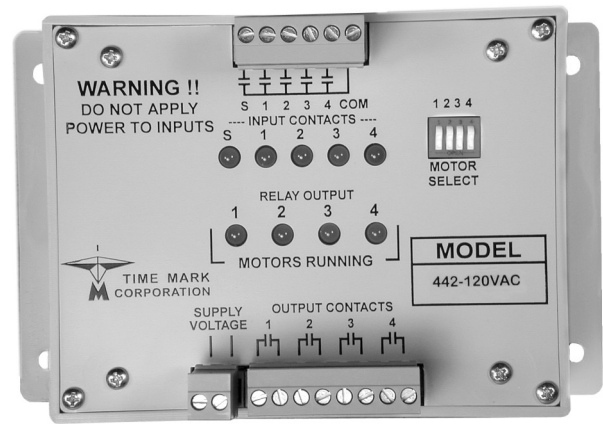
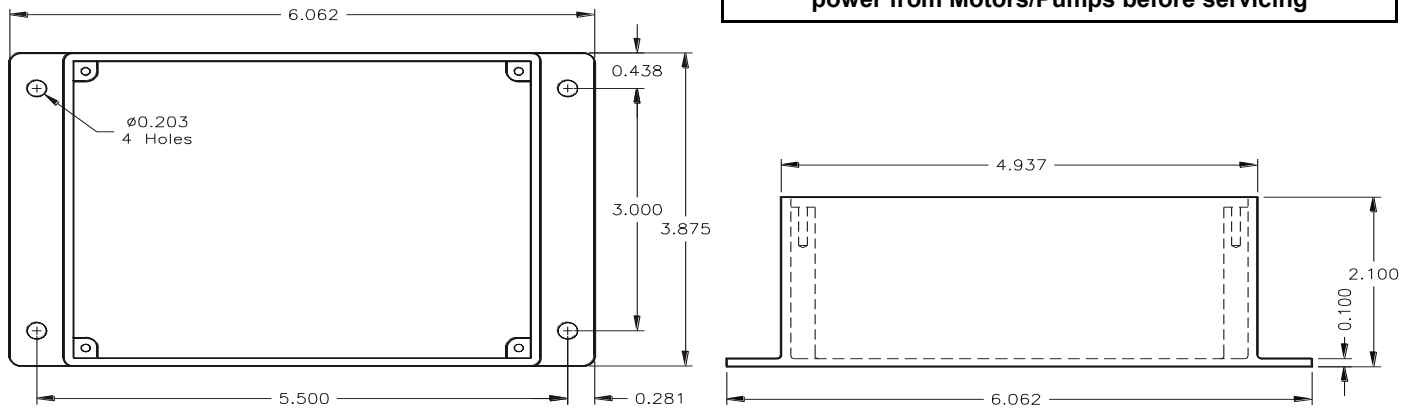

SPECIFICATIONS

MODEL	442-120	442-240
Input Voltage	120VAC +/- 10% 50/60Hz	240VAC +/- 10% 50/60Hz
Power Consumption	6.0 watts max.	
Transient Protection	2500 VRMS for 10ms	
Delay Between Relay Operations	5 seconds	
Output Contact Rating	SPST 5A at 240VAC or 5A at 30VDC resistive	
Input Contact Requirement	0.001 amp at 12VDC	
Expected Relay Life	Mech: 50 million operations Elec: 100,000 ops at rated load	
Operating Temperature	- 20° to +140° F	
Humidity Tolerance	0 - 97% w/o condensation	
Enclosure Material	ABS plastic	
Weight	1.0 lbs.	

Motor/Pump Select Switch

OFF (open)	Motor/pump disabled (unit will not try to use that motor)
ON (closed)	Motor/pump enabled (unit will operate relay for motor as needed)

The Model 442 is not a personal safety device. Remove power from Motors/Pumps before servicing

Telephone: Main - (918) 438-1220
Sales - (800) 862-2875
Fax: (918) 437-7584

E-mail: sales@time-mark.com
Internet: http://www.time-mark.com



TIME MARK
CORPORATION

11440 East Pine Street
Tulsa, Oklahoma 74116

Page 1 of 3 11/2011
© 2011 TIME MARK CORPORATION

TIME MARK is a division of  **AEMT, Inc.**

MODEL 442 Multi-Stage Alternator

READ ALL INSTRUCTIONS BEFORE INSTALLING, OPERATING OR SERVICING THIS DEVICE.
KEEP THIS DATA SHEET FOR FUTURE REFERENCE.

GENERAL SAFETY

POTENTIALLY HAZARDOUS VOLTAGES ARE PRESENT AT THE TERMINALS OF THE MODEL 442.
ALL ELECTRICAL POWER SHOULD BE REMOVED WHEN CONNECTING OR DISCONNECTING WIRING.
THIS DEVICE SHOULD BE INSTALLED AND SERVICED BY QUALIFIED PERSONNEL.

Installation Instructions

INSTALLATION

Switch Inputs			
Input 1	First level input	Input 3	Third level input
Input 2	Second level input	Input 4	Fourth level input
COM	Supply voltage output to switches 12VDC		
S	Stop switch input		
** DO NOT APPLY VOLTAGE TO SWITCH INPUTS **			
Switch Fault Detection (BLINKING LIGHT):			
STOP	Switch stuck OFF only		
1 - 4	Switch stuck ON or OFF		
If fault clears, LED will stop blinking			

Mount the Model 442 in an appropriate enclosure or panel.

Do not apply power until all other connections are made.

Connect the input switches (float, pressure, etc.) to the terminals marked INPUT CONTACTS.

One side of each input switch is connected to the common terminal; the other side should be connected to the input terminals, starting with terminal 1.

Terminal 1 will be the first selected for either the pump up or the pump down application. See the TYPICAL APPLICATION diagram.

Connect the control circuits of the pumps or motors to be alternated to the terminals marked OUTPUT CONTACTS.

Connect AC power connections to the terminals marked Supply Voltage.

ADJUSTMENT

Set the motor select DIP switches to the ON position, for every Motor/Pump connected to the Model 442 you wish to enable.

If a pump or motor must be removed from service, set the DIP switch to OFF for that motor/pump.

PUMP DOWN APPLICATION

In a "Pump Down" application, the switches are normally-

open. As the liquid level rises, the number 1 level switch closes, turning on the first pump. If the level continues to rise, additional pumps are turned on.

As the level drops, the pumps or motors stay on until the STOP switch opens. When the STOP switch opens, the Model 442 alternates to the next pump for the next operating cycle.

PUMP UP APPLICATION

In a "Pump Up" application, the switches are normally-closed. When the reservoir is full, the switches will be open. As the liquid level drops the number 1 level switch closes, turning on the first pump. If the level continues to drop, additional pumps are turned on.

When the level rises above the STOP switch, the switch opens, turning off all pumps. The Model 442 then alternates to start the next pump in line for the next operating cycle.

WARRANTY

This product is warranted to be free from defects in materials and workmanship for one year. Should this device fail to operate, we will repair it for one year from the date of manufacture. For complete warranty details, see the *Terms and Conditions of Sales* page in the front section of the Time Mark catalog or contact Time Mark at 1-800-862-2875.

TYPICAL APPLICATION

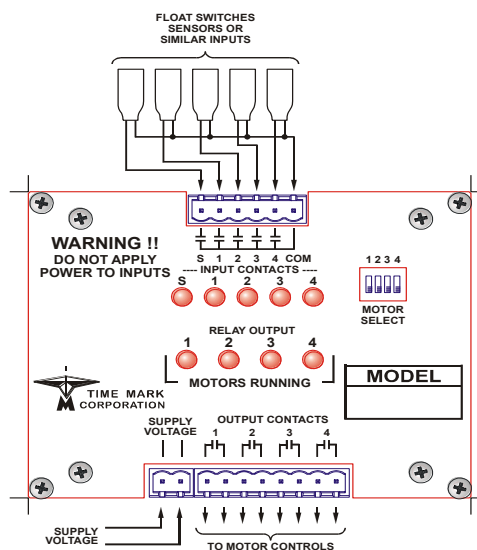

Telephone: Main - (918) 438-1220

Sales - (800) 862-2875

Fax: (918) 437-7584

E-mail: sales@time-mark.com

Internet: http://www.time-mark.com



TIME MARK
CORPORATION

11440 East Pine Street
Tulsa, Oklahoma 74116

Page 2 of 3 11/2011

© 2011 TIME MARK CORPORATION

TIME MARK is a division of  AEMT, Inc.

MODEL 442 Multi-Stage Alternator

READ ALL INSTRUCTIONS BEFORE INSTALLING, OPERATING OR SERVICING THIS DEVICE.
KEEP THIS DATA SHEET FOR FUTURE REFERENCE.

GENERAL SAFETY

POTENTIALLY HAZARDOUS VOLTAGES ARE PRESENT AT THE TERMINALS OF THE MODEL 442.
ALL ELECTRICAL POWER SHOULD BE REMOVED WHEN CONNECTING OR DISCONNECTING WIRING.
THIS DEVICE SHOULD BE INSTALLED AND SERVICED BY QUALIFIED PERSONNEL.

TYPICAL PUMP DOWN APPLICATION - SOSO Operation w/STOP & 2 Float Switches

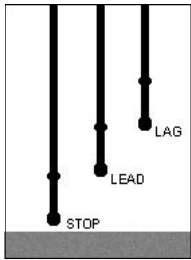

Step 1

In this example, the three normally open dry float switches are designated Stop, Lead and Lag. All switches begin open and Load 1 and Load 2 are de-energized. (Two loads are shown. You could also hook up Load 3 and Load 4)

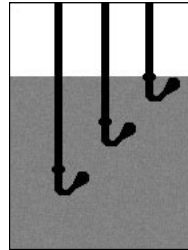

Step 4

Fluid levels continue to rise, LAG float switch closes, energizes 2nd load, lights red input switch LED (LAG) and a red Relay Output LED lights indicating which load is currently LAG.

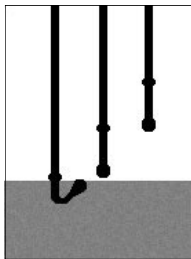

Step 2

Fluid levels begin rising. STOP switch closes, red STOP LED lights indicating switch closure. No loads are energized.

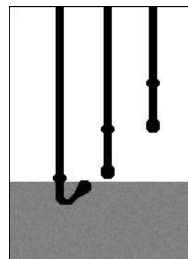

Step 5

As fluid levels fall, LEAD and LAG switches open, loads remain energized until the STOP switch opens. Red switch status LEDs turn off as corresponding switches open.

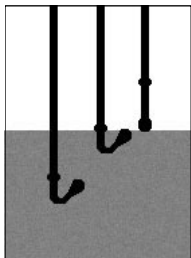

Step 3

Fluid levels continue to rise, Switch 1 (LEAD) closes and energizes 1st load in sequence. Red LED lights indicating float switch closure and a red Relay Output LED lights indicating which load is currently LEAD.

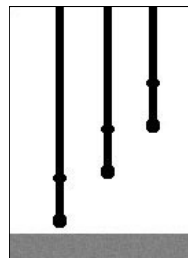

Step 6

Fluid levels fall below the STOP switch, de-energizing all loads and turning off red load status LEDs. Control logic alternates loads between enabled motors to equalize motor usage.

Telephone: Main - (918) 438-1220
Sales - (800) 862-2875
Fax: (918) 437-7584

E-mail: sales@time-mark.com
Internet: <http://www.time-mark.com>



TIME MARK
CORPORATION

11440 East Pine Street
Tulsa, Oklahoma 74116

Page 3 of 3 11/2011
© 2011 TIME MARK CORPORATION

TIME MARK is a division of  AEMT, Inc.

