

Features

- 5.0mm X 5.0mm X 1.2mm SMD LED
- Zener diode provided for ESD protection
- IR-reflow compatible
- Standard Package: 500pcs / Reel
- MSL (Moisture Sensitivity Level): 3
- RoHS compliant



ATTENTION
OBSERVE PRECAUTIONS
FOR HANDLING
ELECTROSTATIC
DISCHARGE
SENSITIVE
DEVICES



Package Schematics

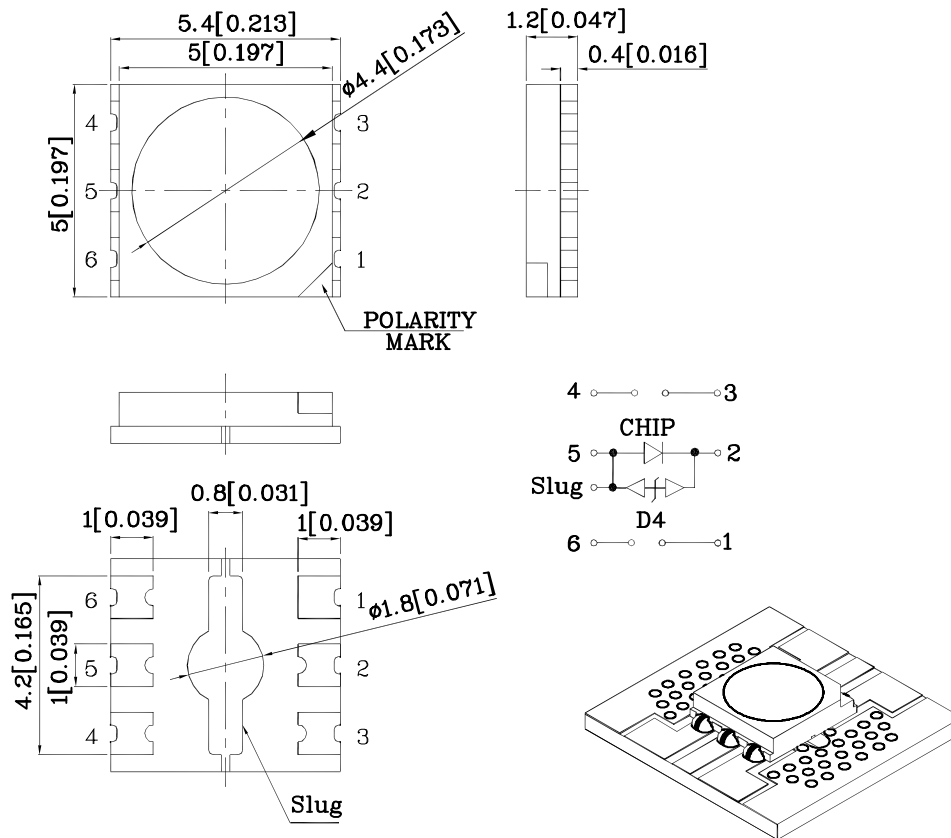

Notes:

1. All dimensions are in millimeters (inches).
2. Tolerance is ±0.25(0.01") unless otherwise noted.
3. Specifications are subject to change without notice.
4. The device has a single mounting surface. The device must be mounted according to the specifications.

Handling Precautions

Compare to epoxy encapsulant that is hard and brittle, silicone is softer and flexible. Although its characteristic significantly reduces thermal stress, it is more susceptible to damage by external mechanical force.

As a result, special handling precautions need to be observed during assembly using silicone encapsulated LED products. Failure to comply might lead to damage and premature failure of the LED.

1. Handle the component along the side surfaces by using forceps or appropriate tools.

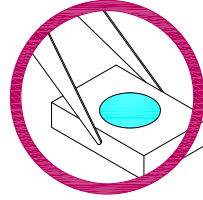

2. Do not directly touch or handle the silicone lens surface. It may damage the internal circuitry.

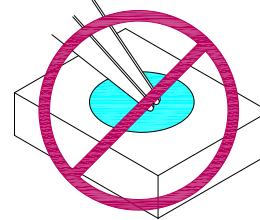
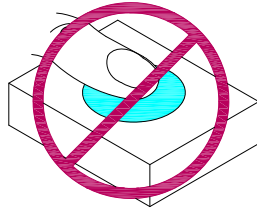

3. Do not stack together assembled PCBs containing exposed LEDs. Impact may scratch the silicone lens or damage the internal circuitry.

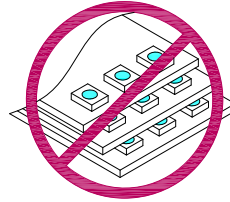

- 4.1. The inner diameter of the SMD pickup nozzle should not exceed the size of the LED to prevent air leaks.
- 4.2. A pliable material is suggested for the nozzle tip to avoid scratching or damaging the LED surface during pickup.
- 4.3. The dimensions of the component must be accurately programmed in the pick-and-place machine to insure precise pickup and avoid damage during production.

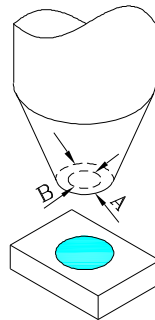

5. As silicone encapsulation is permeable to gases, some corrosive substances such as H₂S might corrode silver plating of leadframe. Special care should be taken if an LED with silicone encapsulation is to be used near such substances.

Part Number	Dice	Lens-color	Luminous Intensity (I _F =350mA) [2]		Luminous Flux (I _F =350mA)*[2]		Viewing Angle 2 θ 1/2 [1]
			Min.	Typ.	Min.	Typ.	
XZDG10X146S	Green (AlGaInN)	Water Clear	10	13.5	38	48	120°

Notes:

1. θ 1/2 is the angle from optical centerline where the luminous intensity is 1/2 of the optical peak value.
2. Luminous intensity / luminous flux: +/-15%.*LEDs are binned according to their luminous flux.

Absolute Maximum Ratings at TA=25°C

Parameter	Symbol	Value	Unit
Power Dissipation	P _D	1.33	W
DC Forward Current [1]	I _F	350	mA
Peak Forward Current [2]	I _{FP}	500	mA
Reverse Voltage	V _R	5	V
Junction temperature	T _J	110	°C
Operating Temperature	T _{op}	-40 To +100	°C
Storage Temperature	T _{stg}	-40 To +110	°C
Thermal Resistance [1]	R _{th j-a}	78	°C/W

Notes:

1. Results from mounting on metal core PCB, mounted on pc board-metal core PCB is recommend for lowest thermal resistance.
2. 1/10 Duty Cycle, 0.1ms Pulse Width.

Electrical / Optical Characteristics at TA=25°C

Parameter	Symbol	Value	Unit
Wavelength at peak emission I _F = 350mA [Typ.]	λ _{peak}	520	nm
Dominant Wavelength I _F = 350mA [Typ.]	λ _{dom} [1]	530	nm
Spectral bandwidth at 50% Φ _{REL MAX} I _F = 350mA [Typ.]	Δλ	35	nm
Forward Voltage I _F =350mA [Min.]	V _F [2]	2.7	V
Forward Voltage I _F =350mA [Typ.]		3.3	
Forward Voltage I _F =350mA [Max.]		3.8	
Allowable Reverse Current [Max.]	I _R	85	mA
Temperature coefficient of λ _{peak} I _F = 350mA, - 10°C ≤ T ≤ 100°C [Typ.]	TCλ _{peak}	0.16	nm/°C
Temperature coefficient of λ _{dom} I _F = 350mA, - 10°C ≤ T ≤ 100°C [Typ.]	TCλ _{dom}	0.14	nm/°C
Temperature coefficient of V _F I _F = 350mA, - 10°C ≤ T ≤ 100°C [Typ.]	TC _v	-3.1	mV/°C

Notes:

- 1.Wavelength : +/-1nm.
2. Forward Voltage: +/-0.1V.

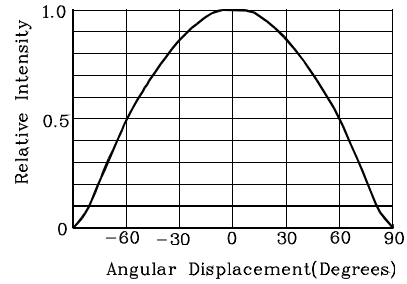
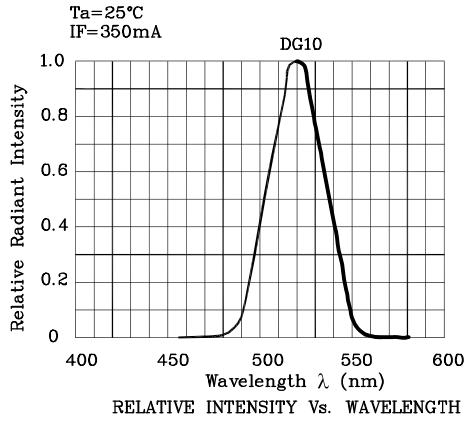

❖ DG10

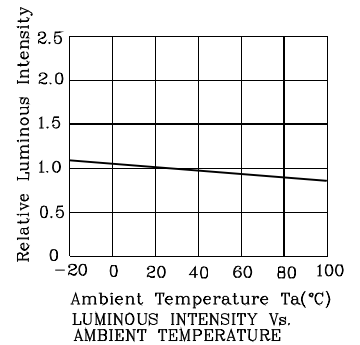
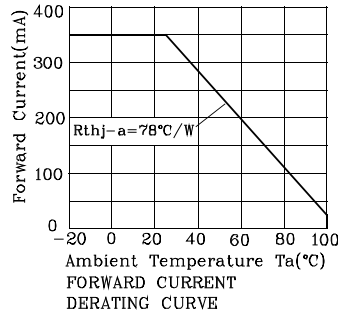
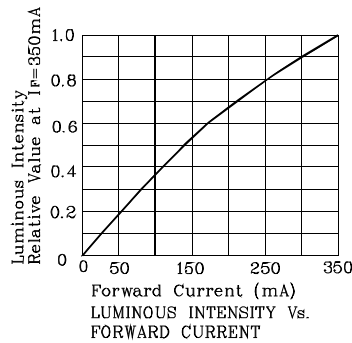
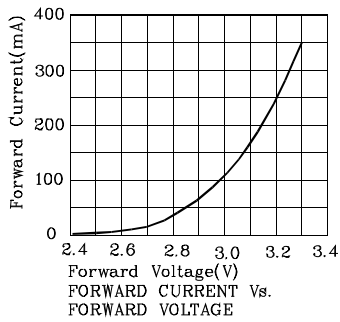

LED is recommended for reflow soldering and soldering profile is shown below.

Reflow Soldering Profile for SMD Products (Pb-Free Components)

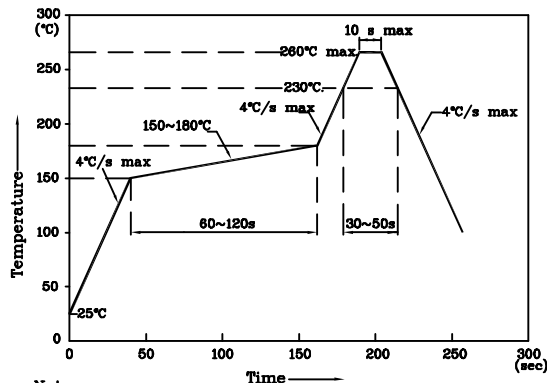

Notes:

1. Maximum soldering temperature should not exceed 260°C
2. Recommended reflow temperature: 145°C-260°C
3. Do not put stress to the epoxy resin during high temperatures conditions



❖ Recommended Soldering Pattern
(Units : mm; Tolerance: ± 0.1)

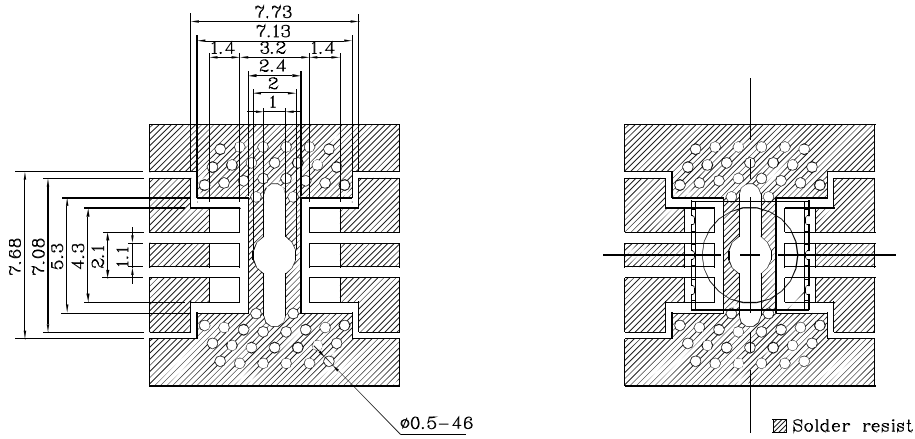

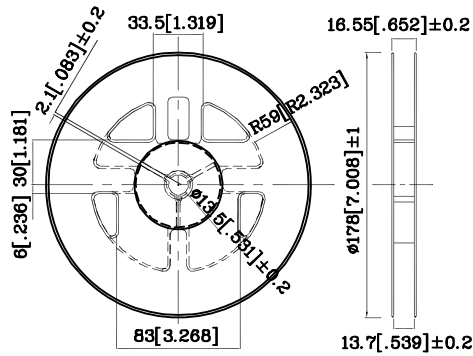

❖ Reel Dimension



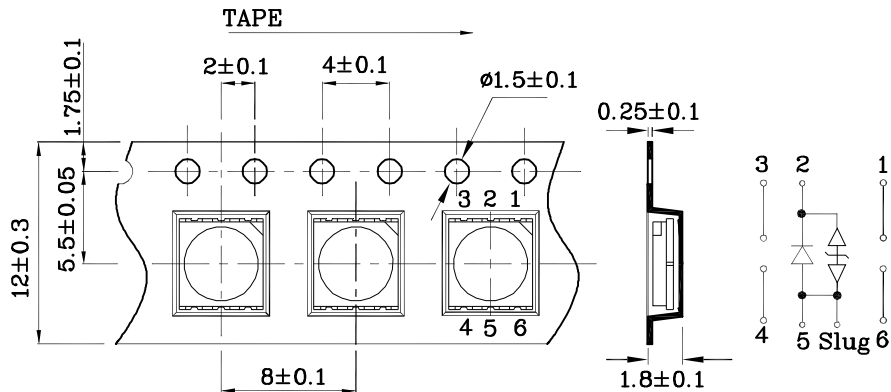

❖ Tape Specification (Units : mm)

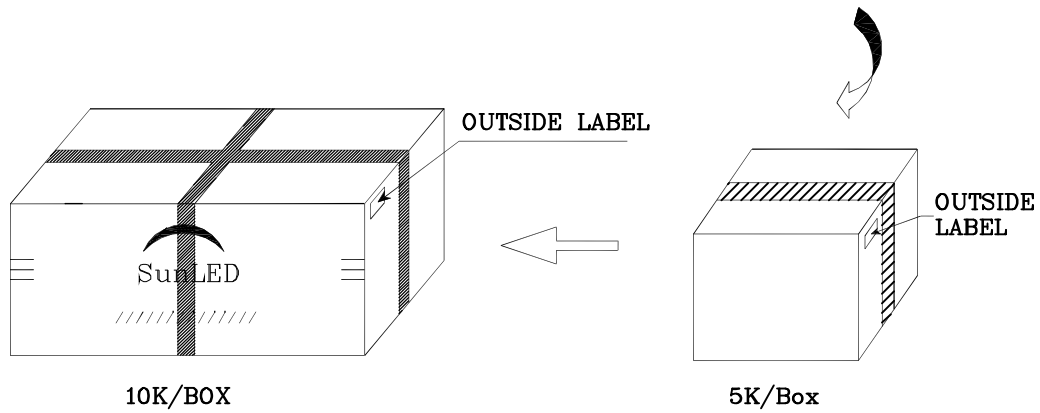
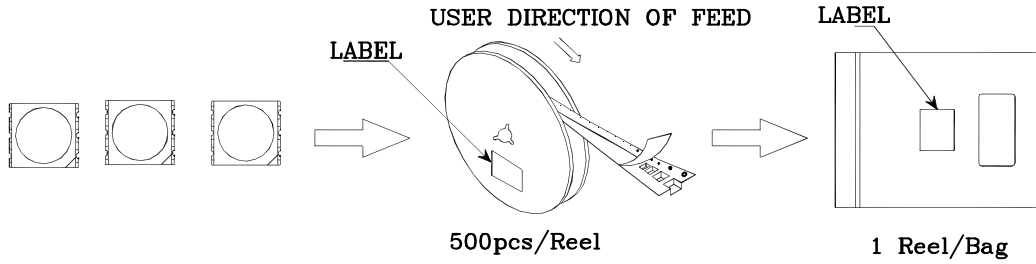

PACKING & LABEL SPECIFICATIONS

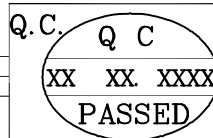
	
P/NO : XZxxx146x	
QTY : 500 pcs	CODE: XXX
S/N : XX	
LOT NO :	
 XXXXXXXXXXXXXXXXXXXXXXXXXXXX	
RoHS Compliant	