

LEVERS FOR ROTARY LIMIT SWITCHES

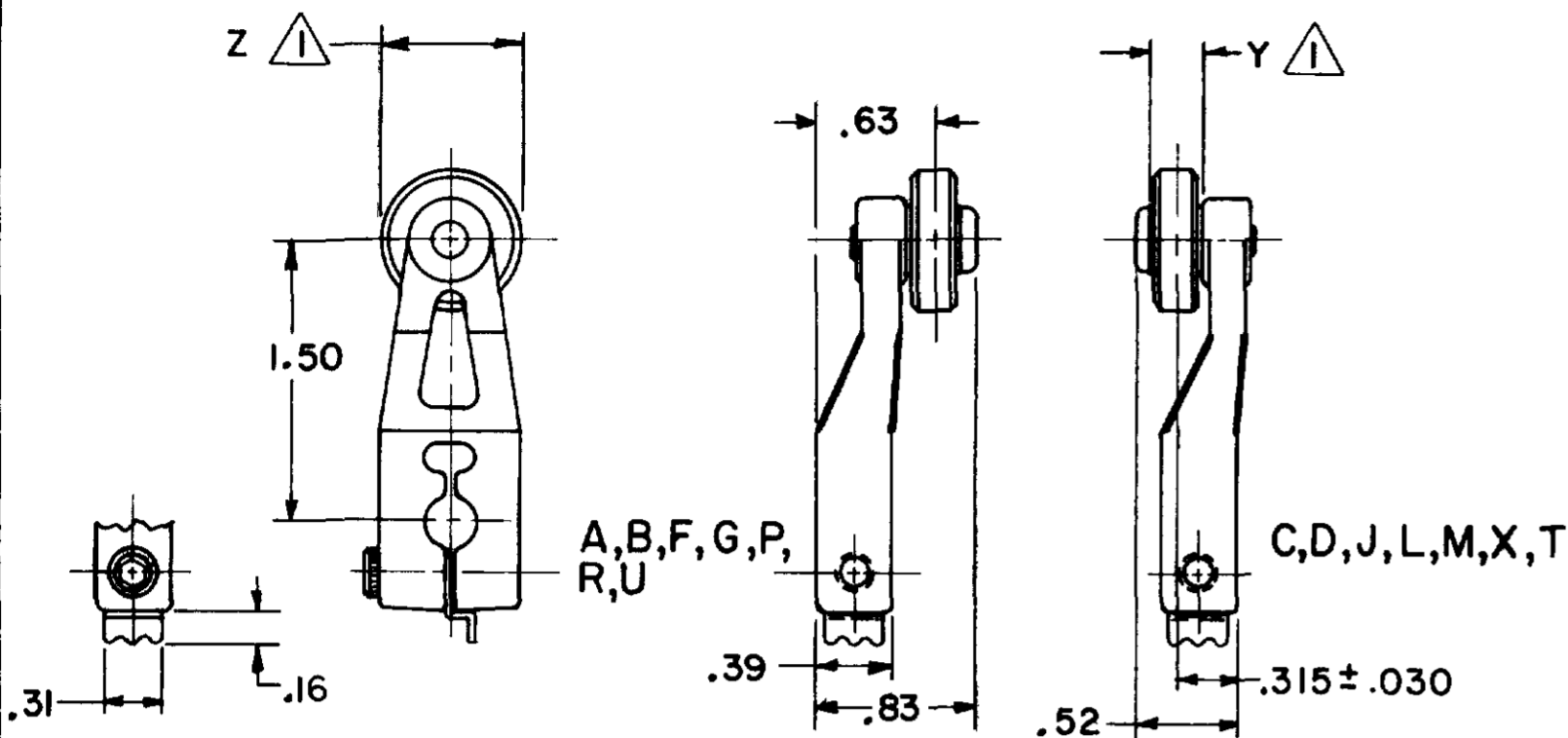

CATALOG LISTING	ROLLER	Z DIA.	Y WIDTH
LSZ51U	ST STEEL	.750	.575
LSZ51	NONE	---	---
LSZ51A	NYLON	.750	.250
LSZ51B	STEEL	.750	.250
LSZ51C	NYLON	.750	.250
LSZ51D	STEEL	.750	.250
LSZ51F	NYLON	1.000	.520
LSZ51G	NYLON	1.500	.250
LSZ51J	NYLON	1.000	.520
LSZ51L	BALL BEARING	.750	.250
LSZ51M	NYLON	.750	1.250
LSZ51P	NYLON	.750	.500
LSZ51N	STEEL	.750	.250
Ⓢ	ST. STEEL	.750	.250
LSZ51T	ST. STEEL	.750	.375
LSZ51R	NYLON	1.59	.250
LSZ51W	RUBBER	1.60	.50
LSZ51Y	RUBBER	2.00	.50

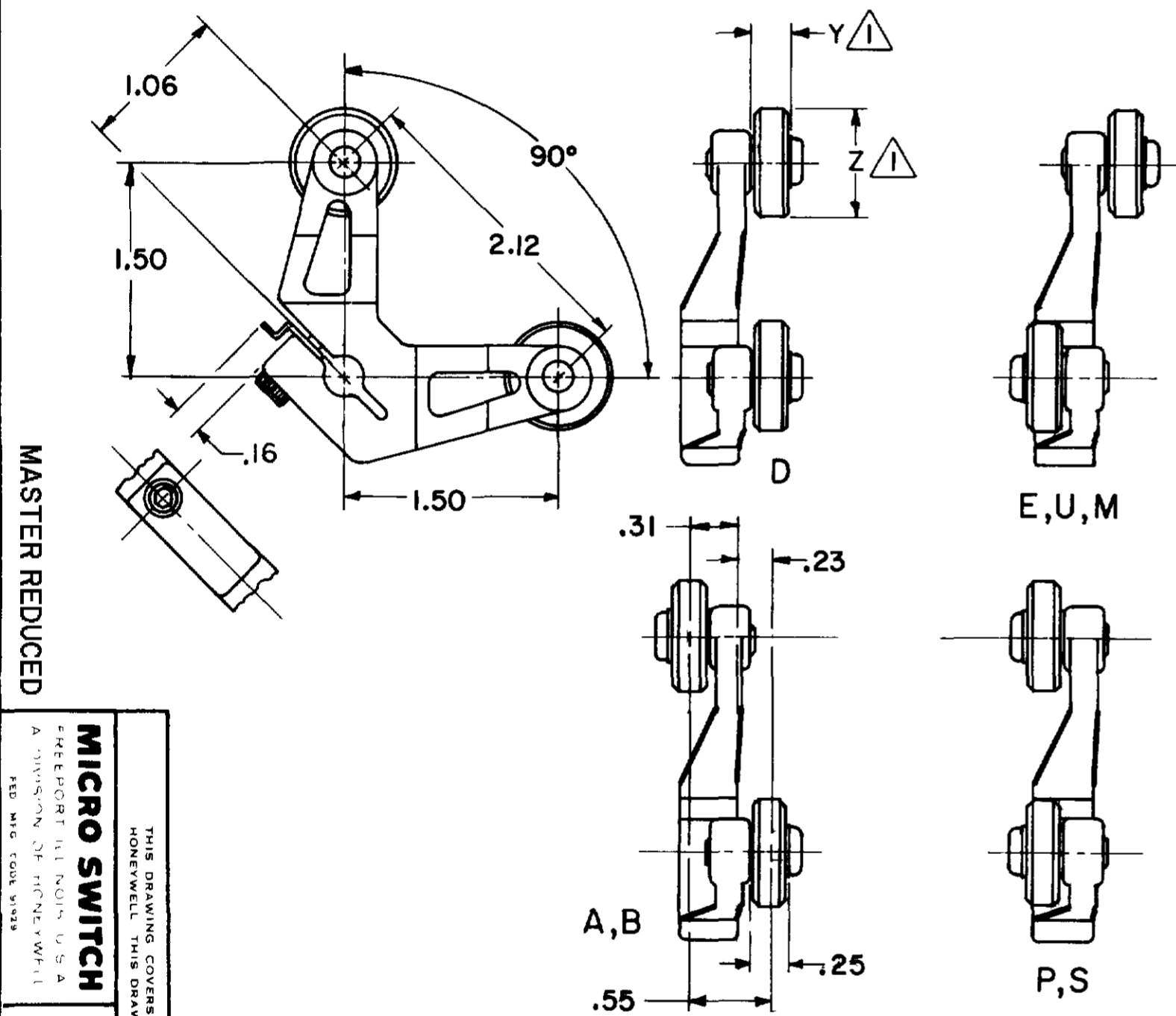

CATALOG LISTING	ROLLER	Z DIA.	Y WIDTH
LSZ53	NONE	---	---
LSZ53A	NYLON	.750	.250
LSZ53B	STEEL	.750	.250
LSZ53D	STEEL	.750	.250
LSZ53E	NYLON	.750	.250
LSZ53P	STEEL	.750	.250
LSZ53S	NYLON	.750	.250
LSZ53U	STEEL	.750	.250
LSZ53M	NYLON	.750	1.250

NOTES
 1 FOR ADDITIONAL ROLLER WIDTHS AND/OR DIAMETERS, REFER TO THE CHART ON THE RIGHT
 2 ALL SCREWS ARE #8-32 UNC WITH A 9/64 ALLEN HEAD SOCKET
 3 SAME AS 6PA121 (6PA121 NOT SHOWN)

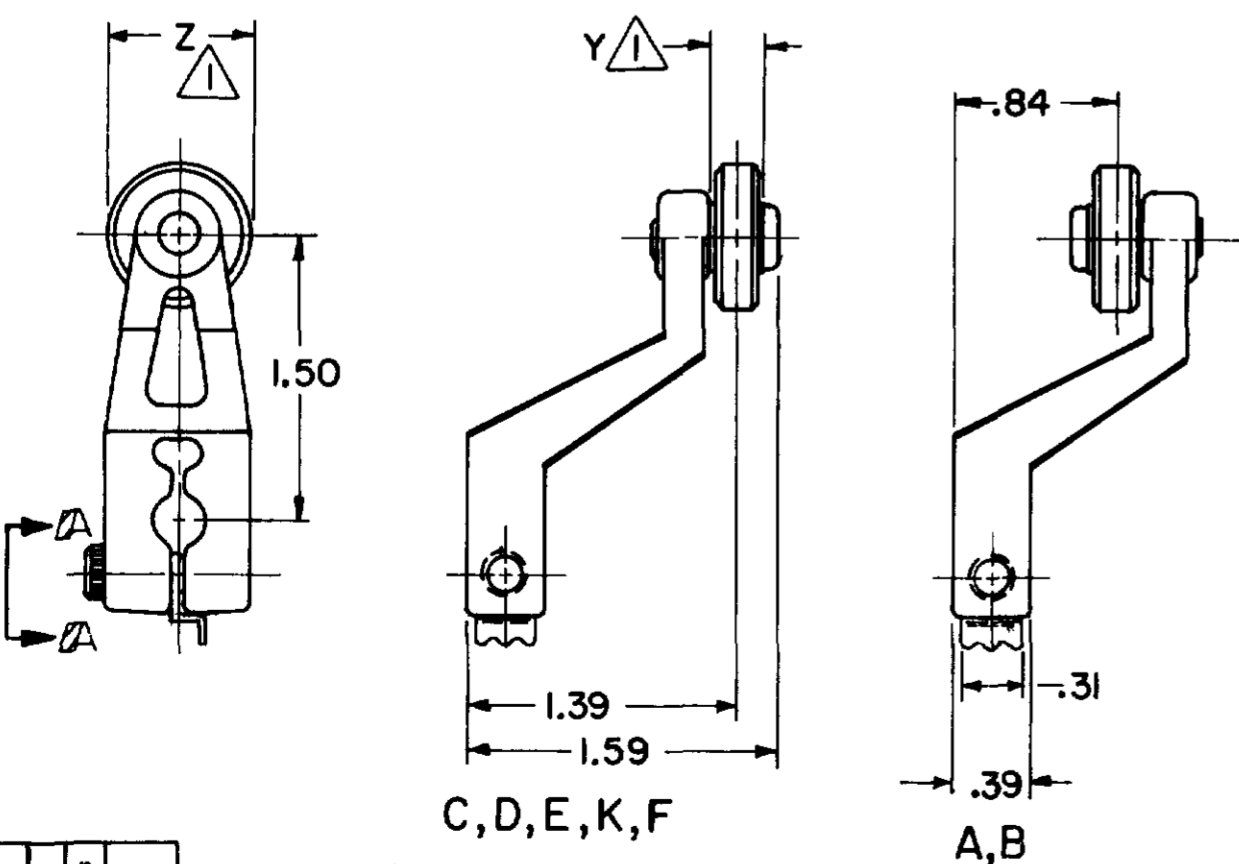

CATALOG LISTING	ROLLER	Z DIA.	Y WIDTH
LSZ55	NONE	---	---
LSZ55A	NYLON	.750	.250
LSZ55B	STEEL	.750	.250
LSZ55C	NYLON	.750	.250
LSZ55D	STEEL	.750	.250
LSZ55E	NYLON	.750	.500
LSZ55K	NYLON	1.500	.250
LSZ55F	NYLON	1.00	.500
LSZ55W	RUBBER	1.60	.50
LSZ55Y	RUBBER	2.00	.50

MASTER REDUCED

MICRO SWITCH
 A DIVISION OF MICRO SWITCH DIVISION OF
 FEDERAL POINT, OHIO 44130 U.S.A.
 MICRO SWITCH DIVISION OF FEDERAL POINT, OHIO 44130 U.S.A.

LSZ SERIES
 CHART 1

LSZ SERIES CHART 1

RASTER

DRAWN

GJW

24 AUG 94

CHECK

JAF

12 SEP 94

CHECK

AK

19 NOV 04

CHECK

RELEASE NO

CO-78499

REPLACES

LSZ SERIES CHT 1

ISSUE **M** CATALOG LISTING
18 LSZ SERIES CHART 1
 PAGE 3 OF 3

LEVERS FOR ROTARY LIMIT SWITCHES

TYPE LSZ59 LEVER

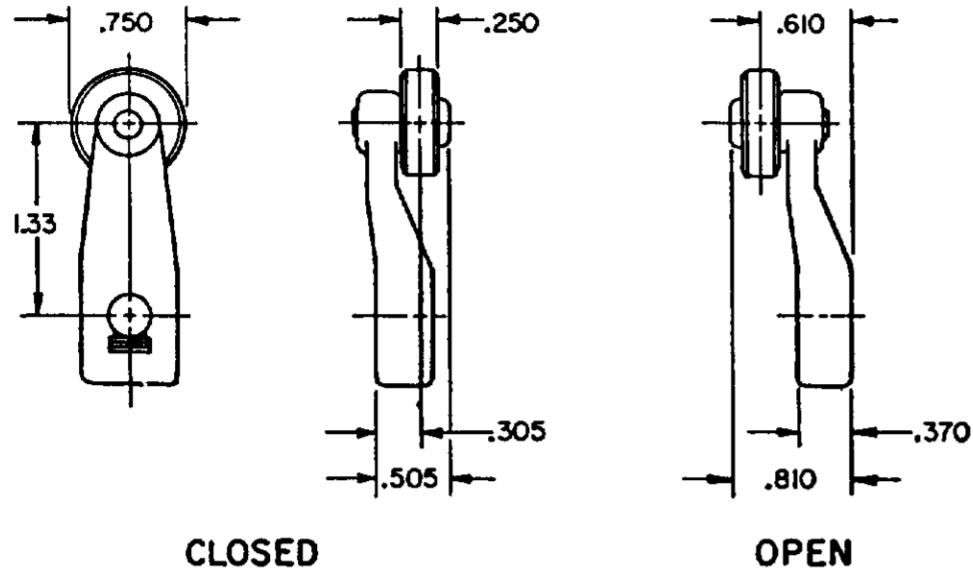

CATALOG LISTING	ROLLER	STYLE	DIA.	WIDTH
LSZ59	NONE	---	----	----
LSZ59A	NYLON	OPEN	.750	.250
LSZ59B	STEEL	OPEN	.750	.250
LSZ59C	NYLON	CLOSED	.750	.250
LSZ59D	STEEL	CLOSED	.750	.250
LSZ59L	BALL BEARING	CLOSED	.750	.250

MASTER REDUCED

FIXED LEVER TYPE

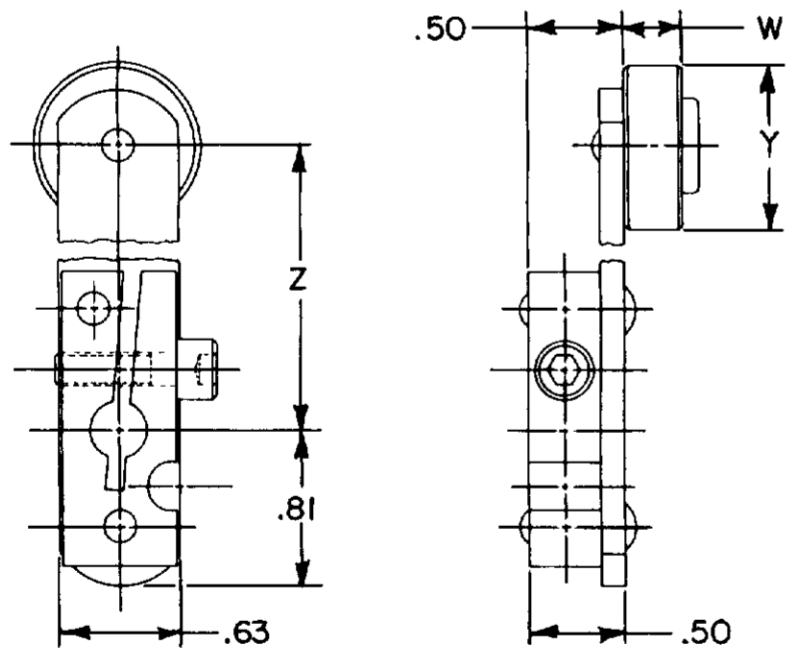

CATALOG LISTING	ROLLER	W WIDTH	Y DIA	Z LENGTH
ⓐ	NYLON	.300	.875	1.500
ⓑ	NYLON	.300	.875	2.000
ⓒ	NYLON	.300	.875	2.500
ⓓ	NYLON	.300	.875	3.000
ⓔ	NYLON	.300	.875	3.500
ⓕ	NYLON	.300	.875	4.000
LSZ581B	ST. STL	.250	.750	1.500
ⓖ	ST. STL	.250	.750	2.000

NOTE
 1 - SCREW IS 10-32 WITH A 5/32 ALLEN HEAD SOCKET

MICRO SWITCH
 FREEPORT, ILLINOIS, U.S.A.
 A DIVISION OF HONEYWELL
 FED. MFG. CODE 9122

THIS DRAWING COVERS A PROPRIETARY ITEM AND IS THE PROPERTY OF MICRO SWITCH, A DIVISION OF HONEYWELL. THIS DRAWING IS NOT TO BE COPIED OR USED WITHOUT THE APPROVAL OF MICRO SWITCH.

LSZ SERIES
 CHART 1

THIRD ANGLE PROJECTION	SCALE	NONE
DO NOT SCALE PRINT	DESIGN UNITS	1/16 INCH
TOLERANCES	UNLESS OTHERWISE SPECIFIED	
FRACTIONS	±.0005	
DECIMALS	±.0005	
ANGLES	±.005	
SPACES	±.005	
WEIGHT	±.005	

M LSZ SERIES CHART 1