

G8015 Series

THIN PROFILE

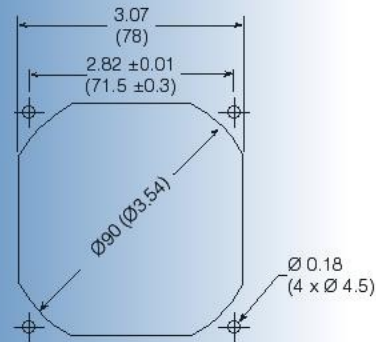
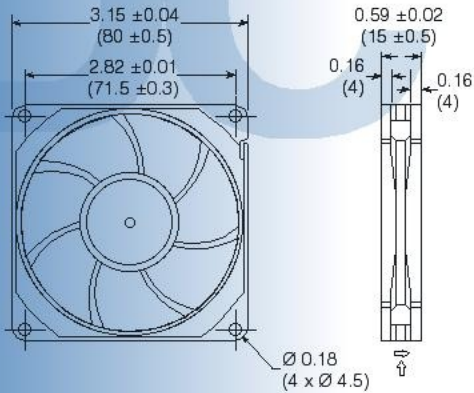

Size: (80 x 80 x 15 mm) 3.15 x 3.15 x 0.59 inches

- High CFM in a thin profile design
- 5, 12 or 24 VDC; impedance protected.
- Ribbed frame style; ball bearing or sleeve bearing models
- Optional tachometer output signal

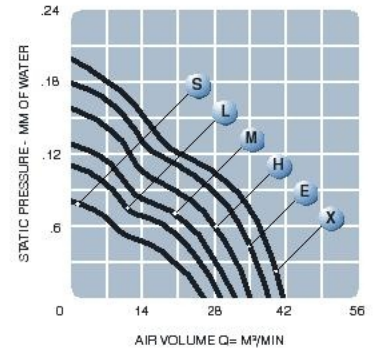

Model No.	Rated Voltage (V)	Current (mA)			Revolution (RPM)	Air Volume (CFM)	Max Static Pressure (In H ₂ O)	Sound Noise (dBA)	Weight (oz)
		5	12	24					
G8015 S	5/12	180	80	-	2,800	26	0.08	29	2.25
G8015 L	5/12/24	280	120	75	3,200	29	0.11	32	2.25
G8015 M	5/12/24	360	150	90	3,600	32	0.13	34	2.25
G8015 H	5/12/24	430	180	120	4,000	35	0.16	36	2.25
G8015 E	5/12/24	550	230	150	4,400	39	0.18	38	2.25
G8015 X	12/24	-	300	180	4,800	42	0.20	40	2.25