

Insulator Color: Pantone 701C (Pink)
See PC99 spec

Materials and Finish

Housing: polyamide,
UL 94V-0 rated,
reflow process compatible,
Color: Pantone 701C (Pink)

Recommended Soldering Temp.:
230°C for 30 seconds,
260°C maximum

Terminals: copper alloy,
silver plating all over
nickel underplating

Mechanical Characteristics

Insertion Force:
3.0kg max.

Extraction Force:
0.2kg min.

Durability: 5000 mating cycles

Electrical Characteristics

Contact Resistance:
Before Test: 50 milliohms max.
After Durability Test:
100 milliohms max.

Rated Voltage:
16 V DC

Rated Current:
0.3A

Insulation Resistance:
100 Megohms min.
at 500V DC

Dielectric Strength:
500V AC RMS for 1 minute

Operating Temp:
-25°C to +85°C

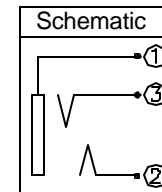
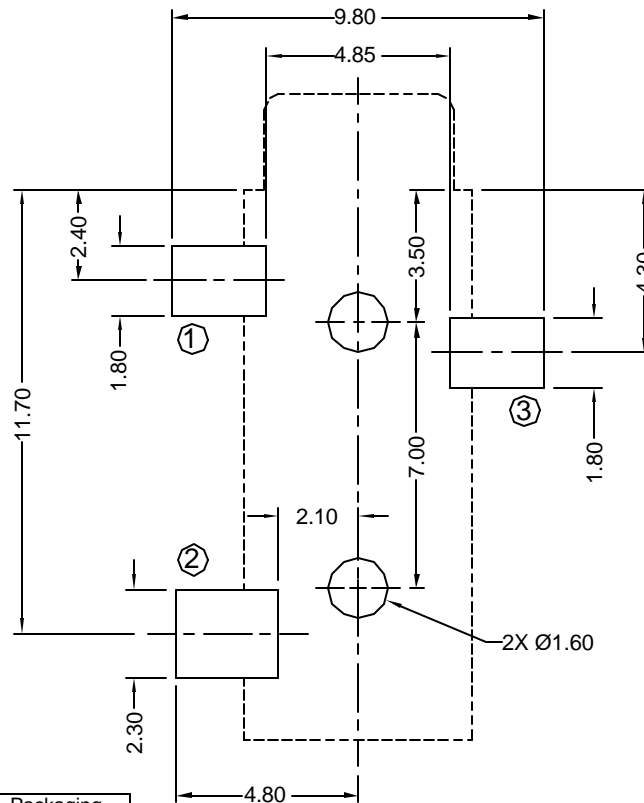
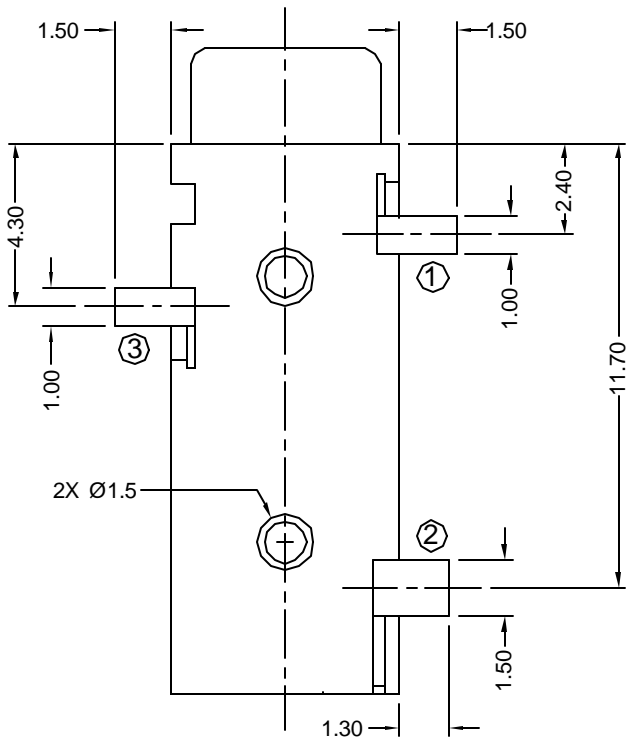

Part Number	Packaging
ST-3500-3N-701C	Bulk
ST-3500-3N-701C-TR	Tape and Reel

Recommended PCB Layout
(Top View)

Tolerances
X.X ± 0.25
X.XX ± 0.15
Unless Stated Otherwise

CSA NRTL/C Certified File No. LR78160

REVISION	DATE	DESCRIPTION	DRAWN BY	CHECKED BY	UNITS
B1	7/17/01	REF ECD 01-123	K. Wallace	C. Leiva	mm
C2	2/6/03	REF ECD 02-140	REVISED BY	CHECK DATE	DATE
D1	2/24/04	REF ECD 04-014	J. Wong	2/25/04	9/16/99

ST-3500-3N-701C

Stereo Jack, 3 position

All Plastic Body, SMT Type, PC99 Color

