

## Weather Proof Cover - Plastic In-Use Weatherproof Cover, Double-Gang, Vrt, 2.25" White

Item WP1220WC



### FEATURES

- ▶ Complies with 2020 NEC Article 314.15 for damp and wet locations
- ▶ UL Certified for Type 3R outdoor enclosures
- ▶ Meets requirements for cold impact testing: -60° F (-51° C)
- ▶ Heavy-duty UV stabilized polycarbonate cover, mounting base and inserts
- ▶ 1/8" (3 mm) thick neoprene gasket with slits for mounting screws
- ▶ Six inserts provided with all models that allow each model to meet multiple installations (up to 70 configurations)
- ▶ Max cord size: (2) #14 AWG or (1) #12 AWG, WP1250 (2) #14 AWG or (1) #10 AWG
- ▶ Warranty: 1-year limited

### APPLICATIONS

- ▶ Receptacle Protection

### TECHNICAL DATA

#### General

Model Number	WP1220WC
Description	Plastic In-Use Weatherproof Cover, Double-Gang, Vrt, 2.25" White
UPC Code	078275140080
Brand	Intermatic
Country of Origin (Intermatic)	MEXICO
Warranty Period	1-Year limited

#### Mechanical Specifications

Number of Included Inserts	6
Insert Types Included	WP217
Hinge Direction	Vertical
Is Extra-Duty Rated	No

#### Dimensions

Product Dimensions (H x W x D) in	5 1/2 x 5 x 2 1/4 in
Accepted Cord Size Max	2x14 AWG; 1x12 AWG
Box Type	Double

#### Material Specifications

Color	White
Weatherproof Cover Material	UV Stabilized Plastic

#### Packaging

Shipping Weight (lbs)	0.559
Unit Carton Dimensions (H x W x L) in	3.001 x 5.501 x 5.501 in

#### Standards and Certifications

UL Certification	UL
------------------	----

California Proposition 65

None

---

## DRAWINGS AND DIAGRAMS

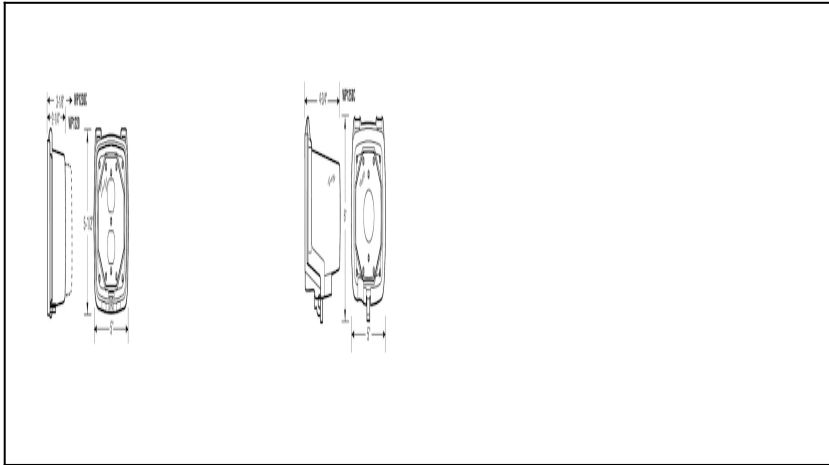

---

## ACCESSORIES



WP217  
Double-Gang Inserts (6)