

# UHD Heavy Duty Disconnect Enclosures - NEMA 12

ABB Controls, Allen Bradley, Cutler Hammer, General Electric, Siemens I-T-E Max-Flex™, Square D

Disconnect

Freestanding Enclosures



3UHD Shown



## Application

- Designed to accept the following disconnect switches and circuit breakers:
- **ABB Controls** flange mounted variable depth operating mechanisms for disconnect switches and circuit breakers.
- **Allen Bradley** 1494F flange mounted disconnect switches and 1494D flange mounted operators for circuit breakers. Allen Bradley 1494V variable depth flange mounted disconnect switches and circuit breaker mechanisms.
- **C-H Westinghouse** type C361 disconnect switches and operator mechanism. Cutler Hammer Type C371 circuit breaker operating mechanisms. Flex-Shaft™ handle operators for circuit breakers.
- **General Electric** type STDA flange handles and variable depth operating mechanisms for disconnect switches and circuit breakers. Also Spectra-Flex™ cable operators for circuit breakers.
- **Siemens I-T-E Max-Flex™** flange mounted variable depth operating handles for disconnect switches and circuit breakers.
- **Square D** disconnect switches and circuit breakers used with Class 9422 flange mounted variable depth operating mechanisms or cable mechanisms. These enclosures will not receive Class 9422 bracket mounted disconnect devices or class 9422TG1 or TG2 devices.

## Standards

- UL 508 Type 12
- CSA Type 12
- **Complies with**
  - NEMA Type 12
  - JIC EGP-1-1967 and EMP-1-1967
  - IEC 60529, IP54
  - Appropriate components are required to maintain these standards.

## Construction

- Formed from 10 gauge steel with smooth, continuously welded seams.
- Body stiffeners are provided in the larger enclosures for extra rigidity.
- Flange trough collar (FTC) around door opening excludes liquids and contaminants.
- Heavy duty lifting eyes are anchored into reinforced top corners.
- Removable doors are secured with heavy duty lift off hinges.
- Formed 10 gauge steel inner panels are provided on collar studs.
- Panel supports are provided.
- Center post is removable, providing easy panel installation.
- Heavy duty three point latching mechanism with heavy duty roller ends is provided for ease of door closing.
- Oil resistant gaskets are permanently secured.
- The right-hand door on all enclosures is the master door.
- Master door handle complete with screw defeater and padlock hasp.
- Slave door handle complete with padlock hasp.

- A mechanical interlock activated by the master door prevents the auxiliary door from being opened first.
- The universal flange cutout provides mounting for disconnect operators by use of the appropriate operator adaptor kit.
- A provision for mounting fluorescent lighting is provided.
- A bonding stud is provided in the door and a grounding stud is provided in the enclosure for each door.
- A literature pocket is provided for the inside of the door.

### Note:

- Disconnect switches, circuit breakers and operators are not provided with the enclosure, and must be ordered separately from the manufacturer.

## Finish

- Door and enclosure are phosphatized and finished in ANSI 61 gray recoatable powder coating on the outside.
- Interior - white powder coating.
- Inner panel is finished in white powder coating.

# 1UHD Heavy Duty Disconnect Enclosures - NEMA 12

ABB Controls, Allen Bradley, Cutler Hammer, General Electric, Siemens I-T-E Max-Flex™, Square D

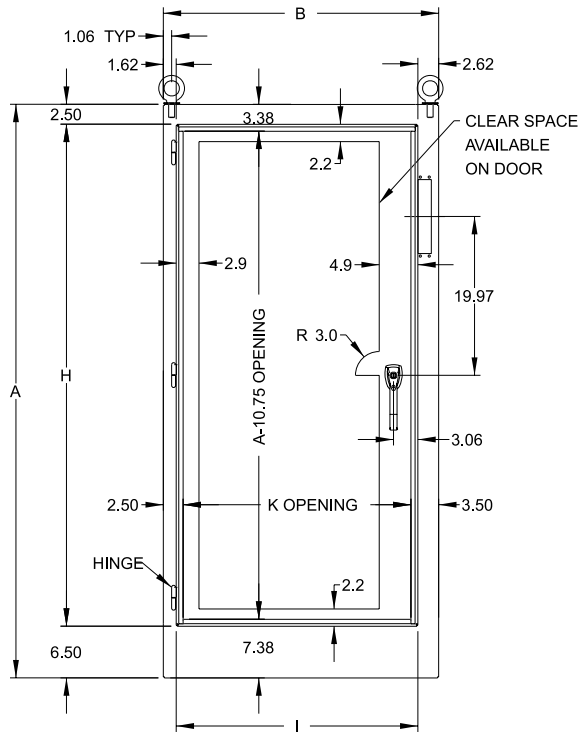

**Front View**

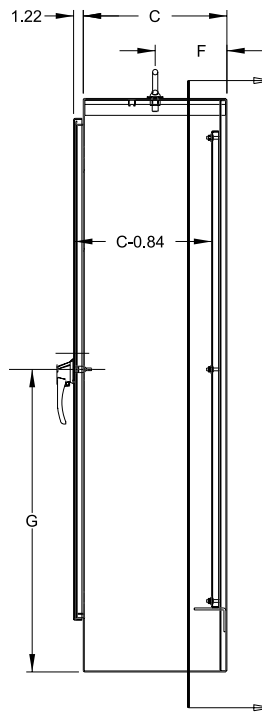

**Side View**

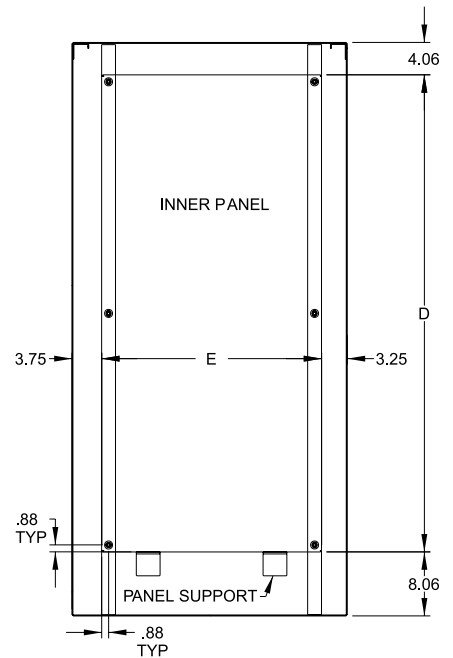

**Rear View (Cross Section)**

Disconnect

Freestanding Enclosures

## Accessories

- Additional inner panels...see factory
- Air conditioners...see page **388-405**
- Blank adaptor plates...see page **188**
- Blowers...see page **407**
- Breather kits...see page **423**
- Doorstop kits...see page **447**
- Enclosure stabilizers...see page **451**
- Filter fans...see page **408-414**
- Floor stand kits...see page **448**
- Heaters...see page **418-420**
- Light kits...see page **447**
- Operator adaptor kits...see page **206**
- Thermostats...see page **421**

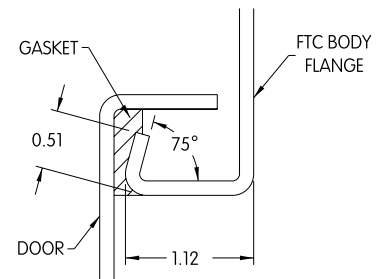

Part No.	Overall Dimensions			Panel Size								Ship Wt. lbs
	A	B	C	D	E	F	G	H	I	K		
<b>1UHD722918FTC</b>	72.13	28.75	18.13	60	21.75	9.06	38.06	63.13	24.5	22.75	433	
<b>1UHD723518FTC</b>	72.13	34.75	18.13	60	27.75	9.06	38.06	63.13	30.5	28.75	499	
<b>1UHD724118FTC</b>	72.13	40.75	18.13	60	33.75	9.06	38.06	63.13	36.5	34.75	565	
<b>1UHD844118FTC</b>	84.13	40.75	18.13	72	33.75	9.06	44.06	75.13	36.5	34.75	650	
<b>1UHD904120FTC</b>	90.13	40.75	20.13	78	33.75	10.06	47.06	81.13	36.5	34.75	718	
<b>1UHD904124FTC</b>	90.13	40.75	24.13	78	33.75	12.06	47.06	81.13	36.5	34.75	766	

# 2UHD Two Door Heavy Duty Disconnect Enclosures - NEMA 12

ABB Controls, Allen Bradley, Cutler Hammer, General Electric, Siemens I-T-E Max-Flex™, Square D

Disconnect

Freestanding Enclosures

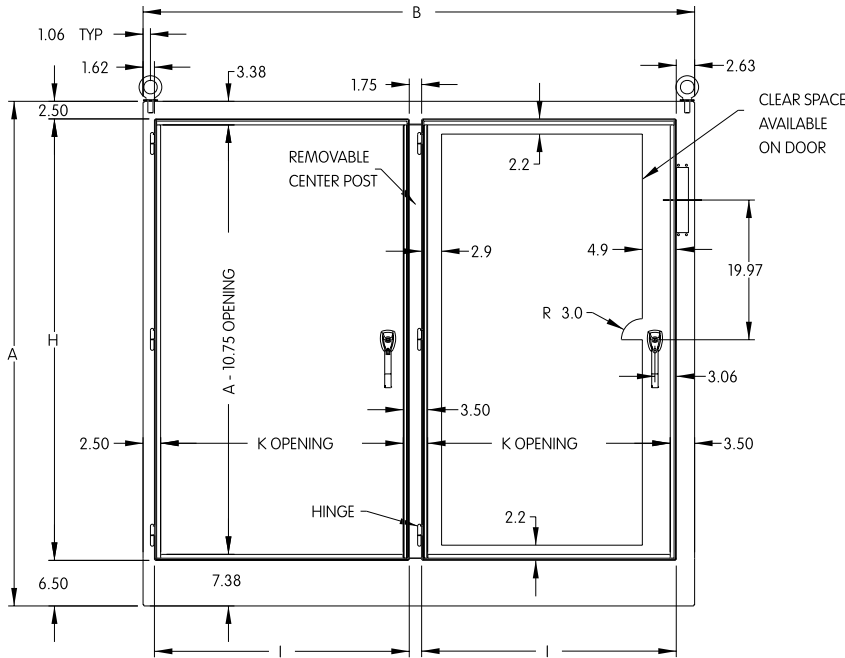

**Front View**

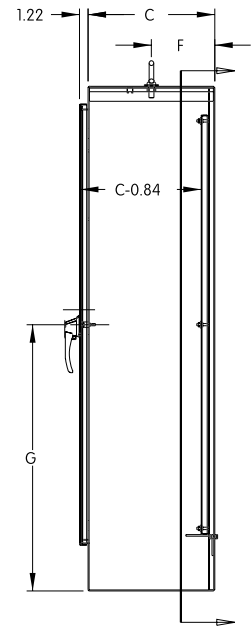

**Side View**

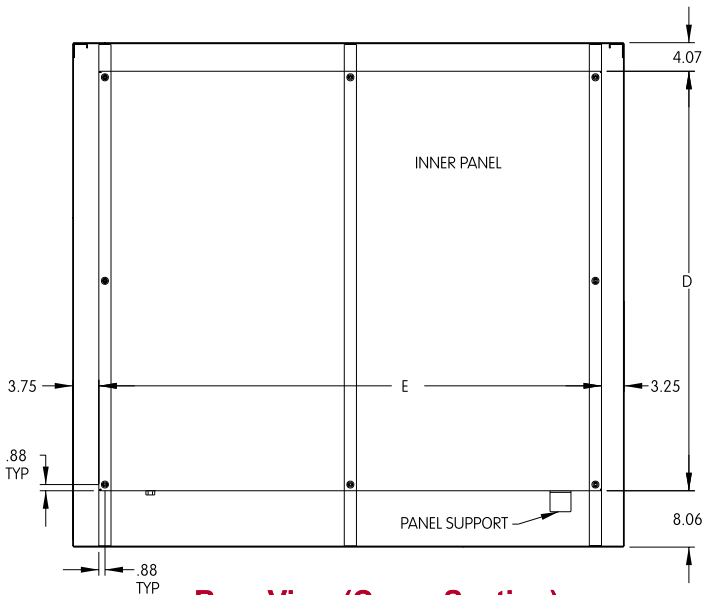

**Rear View (Cross Section)**

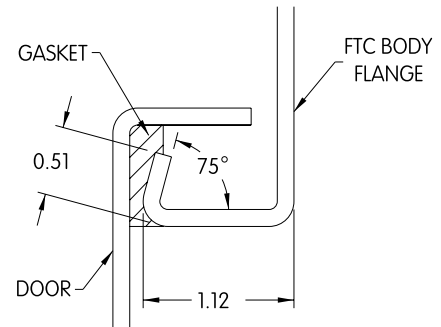

Part No.	Overall Dimensions			Panel Size			G	H	I	K	Ship Wt. lbs
	A	B	C	D	E	F					
2UHD725518FTC	72.13	55	18.13	60	48	9.06	38.06	63.13	24.5	22.75	751
2UHD726718FTC	72.13	67	18.13	60	60	9.06	38.06	63.13	30.5	28.75	903
2UHD727918FTC	72.13	79	18.13	60	72	9.06	38.06	63.13	36.5	34.75	1036
2UHD727924FTC	72.13	79	24.13	60	72	12.06	38.06	63.13	36.5	34.75	1199
2UHD847918FTC	84.13	79	18.13	72	72	9.06	44.06	75.13	36.5	34.75	1121
2UHD907920FTC	90.13	79	20.13	78	72	10.06	47.06	81.13	36.5	34.75	1297
2UHD907924FTC	90.13	79	24.13	78	72	12.06	47.06	81.13	36.5	34.75	1356

Technical references and DXF downloads available at [www.hamfmg.com](http://www.hamfmg.com)

All dimensions in inches unless specified otherwise

# 3UHD Two Door Heavy Duty Disconnect Enclosures - NEMA 12

ABB Controls, Allen Bradley, Cutler Hammer, General Electric, Siemens I-T-E Max-Flex™, Square D

Disconnect

Freestanding Enclosures

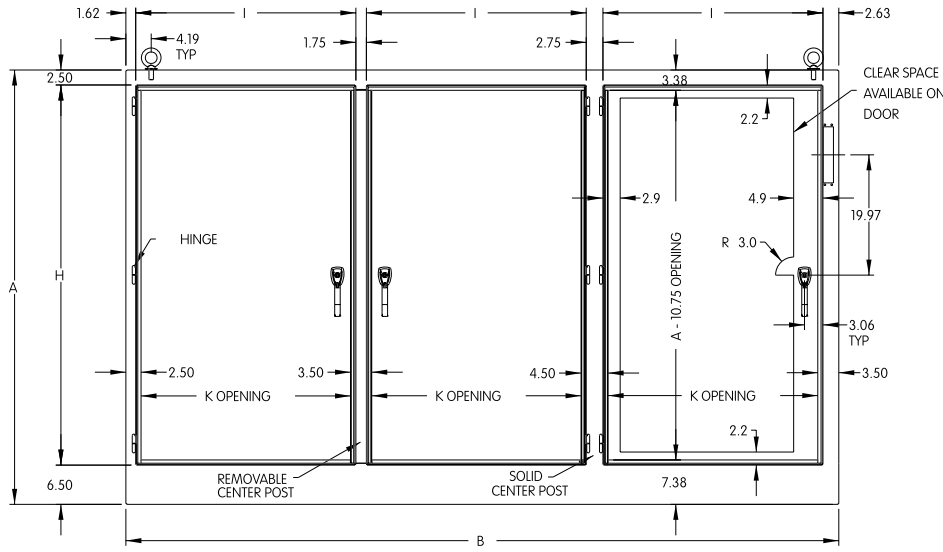

**Front View**

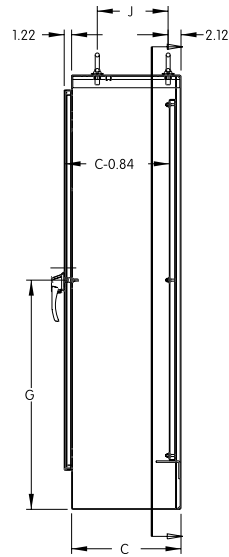

**Side View**

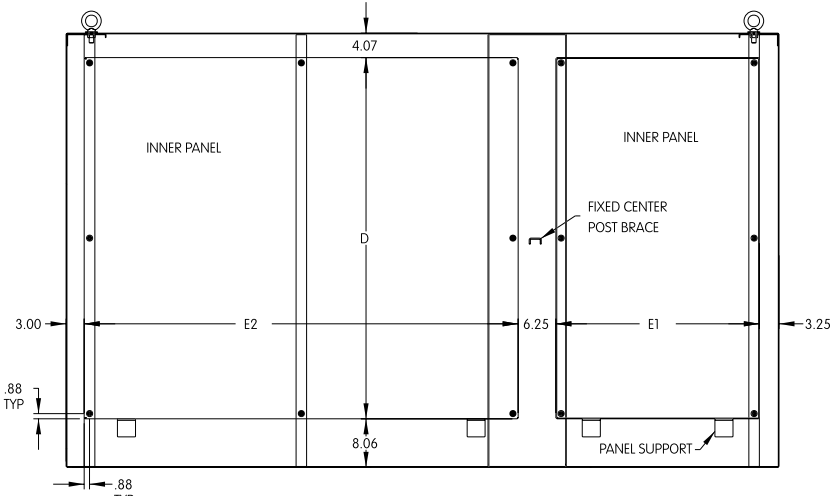

**Rear View (Cross Section)**

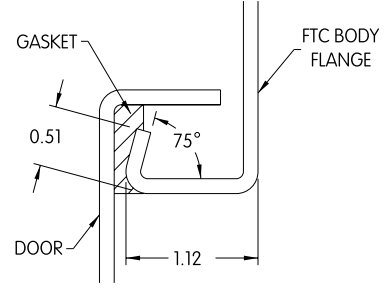

Part No.	Overall Dimensions				Panel Size				Ship Wt. lbs			
	A	B	C	D	E <sup>1</sup>	E <sup>2</sup>	G	H				
<b>3UHD7210118FTC</b>	72.13	100.25	18.13	60	27.75	60	38.06	63.13	30.5	11.75	28.75	1269
<b>3UHD7211918FTC</b>	72.13	118.25	18.13	60	33.75	72	38.06	63.13	36.5	11.75	34.75	1497
<b>3UHD8411918FTC</b>	84.13	118.25	18.13	72	33.75	72	44.06	75.13	36.5	11.75	34.75	1727
<b>3UHD9011924FTC</b>	90.13	118.25	24.13	78	33.75	72	47.06	81.13	36.5	17.75	34.75	1958

# 4UHD Four Door Heavy Duty Disconnect Enclosures - NEMA 12

ABB Controls, Allen Bradley, Cutler Hammer, General Electric, Siemens I-T-E Max-Flex™, Square D

Disconnect

Freestanding Enclosures

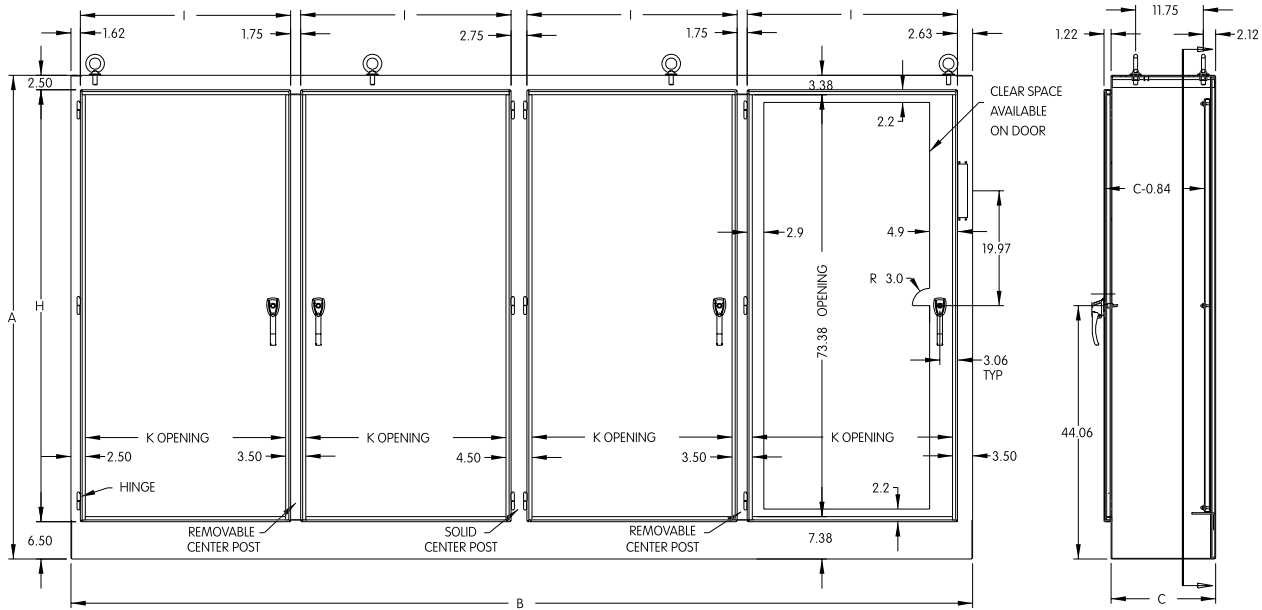

**Front View**

**Side View**

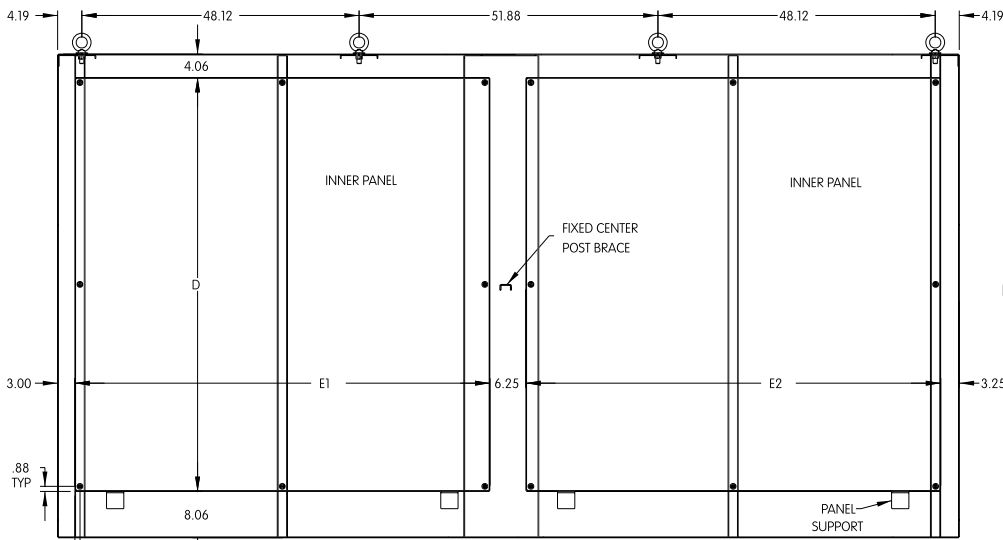

**Rear View (Cross Section)**

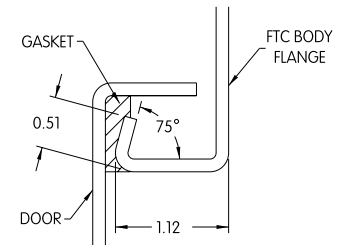

Part No.	Overall Dimensions				Panel Size			I	K	Ship Wt. lbs
	A	B	C	D	E <sup>1</sup>	E <sup>2</sup>	H			
<b>4UHD8415718FTC</b>	84.13	156.5	18.13	72	72	72	75.13	36.5	34.75	2271

Technical references and DXF downloads available at [www.hamfmg.com](http://www.hamfmg.com)

All dimensions in inches unless specified otherwise

# 5UHD Five Door Heavy Duty Disconnect Enclosures - NEMA 12

ABB Controls, Allen Bradley, Cutler Hammer, General Electric, Siemens I-T-E Max-Flex™, Square D

Disconnect

Freestanding Enclosures

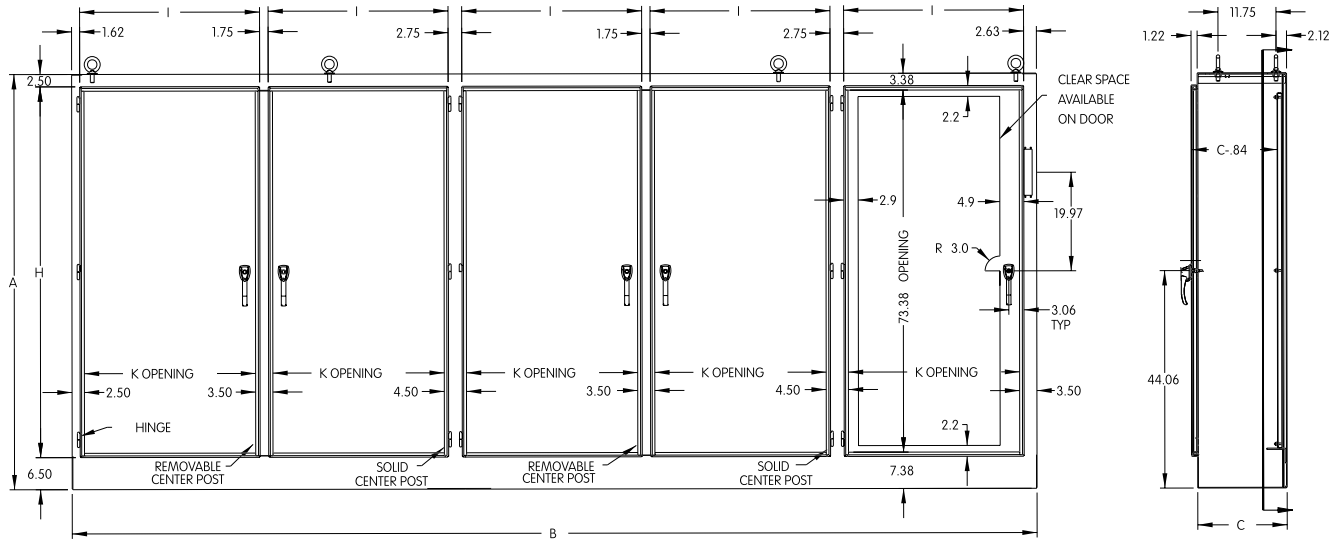

**Front View**

**Side View**

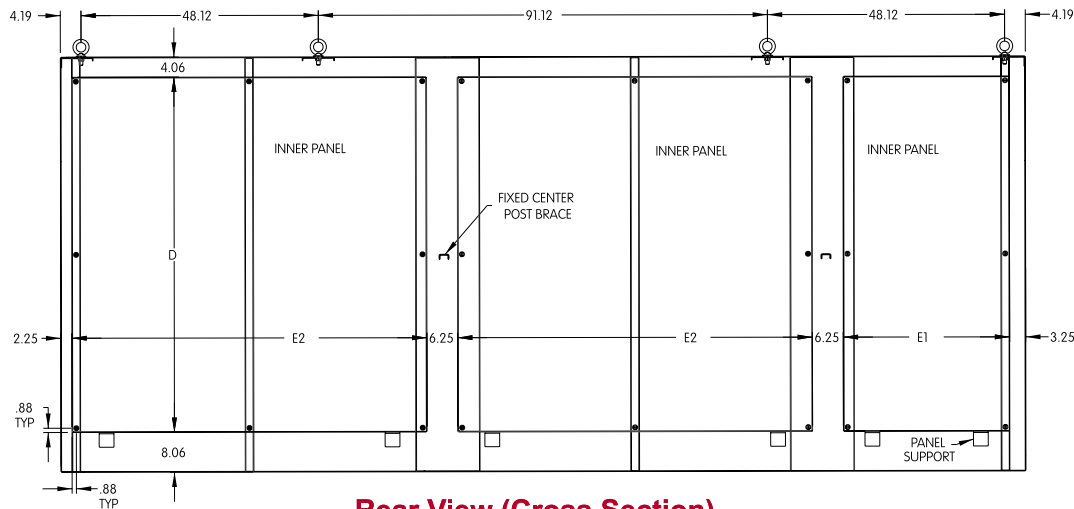

**Rear View (Cross Section)**

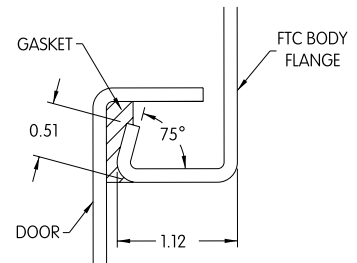

Part No.	Overall Dimensions				Panel Size			Ship Wt. lbs		
	A	B	C	D	E <sup>1</sup>	E <sup>2</sup>	H			
<b>5UHD8419518FTC</b>	84.13	195.75	18.13	72	33.75	72	75.13	36.5	34.75	2820

Technical references and DXF downloads available at [www.hamfmfg.com](http://www.hamfmfg.com)

All dimensions in inches unless specified otherwise

**Quality Enclosures. Service Excellence.**