

1/4" x 1-1/4" Fuseholders

HKP Panel Mount Series

Description

- For 1/4" x 1-1/4" (6.3mm x 32mm) fuses
- Maximum panel thickness 5/16" (7.9mm) thick
- Bayonet-type Knob
- Vibration Resistant
- Military version is designated FHN26G1
- Plastic nut – BK/1A4287
- Metal nut – BK/1A4806-2
- Cap – 9435-1/2
- Neoprene washer – 9732

Agency Information

- UL Recognized: IZLT2, E14853
- CSA Component Acceptance:
Class 6225-01, File 47235

Ordering

- Specify product code and packaging code

Dimensions

Drawing Not to Scale

HKP-BBHH, HKP-HH, HKP-LW-HH

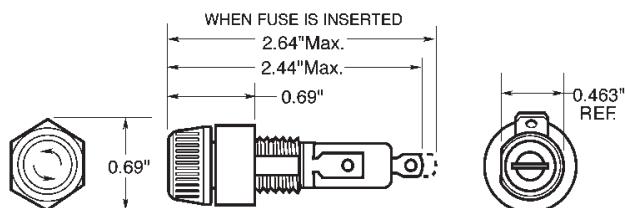

Punched Mounting Hole

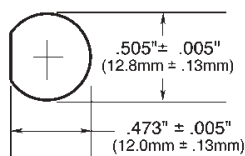

Drilled Mounting Hole

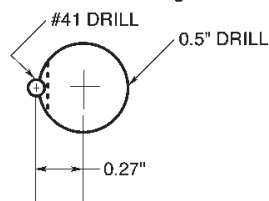

Environmental Data

- Temperature rating (RTI): The mounting body for all devices has a temperature rating of 150°C. The knob for these devices are molded plastic with a temperature rating of 150°C.
- Thermoplastic meets UL 94 HB
- Terminal Strength: 5 pounds
- Torque: Mounting – 20 inch-pound
- Salt Spray (corrosion): Test condition B



HKP, HKP-L, and HKP-W

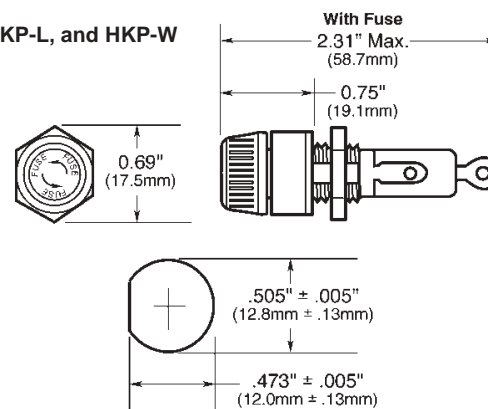

HKP-OO

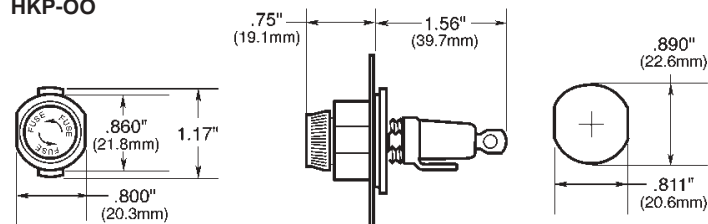

Component	Material
Terminal	Tin-Plated Brass
Body	Thermoset
Cap	Thermoset
Nut	Thermoplastic

SPECIFICATIONS

Product Code	Feature	Voltage Rating	Current Rating
HKP	Standard	250V	30A
HKP-BBHH	1/4" Quick Connects, nut and washer assembled	250V	15A
HKP-HH	1/4" Quick Connects	250V	15A
HKP-L	2250 stand-off barrier	250V	30A
HKP-LW-HH	Drip-proof knob, 2250V stand-off barrier and 1/4" quick connects	250V	15A
HKP-OO	Snap-lock	250V	30A
HKP-W	Drip-proof knob	250V	30A

PACKAGING CODE	
Packaging Code	Description
Blank	10 pieces of fuseholders packed into a carton
BK	100 pieces of fuseholder components packed separately into a carton