

Model 100

STA[®] Push DC Tubular Solenoid

Size: 1" OD X 2" L

ALL PRODUCTS ARE RoHS COMPLIANT

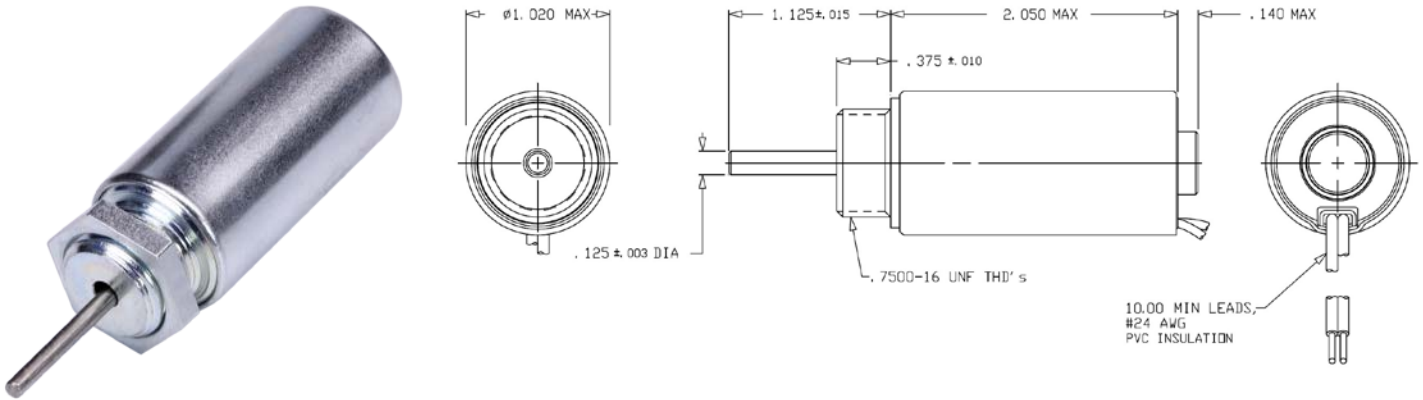

Solenoid shown energized with plunger fully seated
 Supplied with hex nut shipped loose
 Spring kits available (consult factory)

Part No.	Duty Cycle	Voltage	Resistance (Ω) ± 5%	Max On Time	Power (W)	Current (A)
195207-225	Intermittent	12 VDC	4.89	32 Secs	29.4	2.45
195207-228	Continuous	12 VDC	19.20	∞	7.5	0.63
195207-228	Intermittent	24 VDC	19.20	32 Secs	30.0	1.25
195207-231	Continuous	24 VDC	77.40	∞	7.4	0.31

Continuous Duty = 100% "On" Time
 Intermittent Duty = 25% "On" Time
 When ordering please refer to Part No. as listed above
 Please consult factory for custom configurations and other pole face angles

Stroke (in.)	Typical Push Force (oz.)								Holding Force (oz.)
	0.060	0.125	0.250	0.375	0.500	0.625	0.750	1.000	
Continuous Duty	43.2	26.0	11.9	7.7	6.0	4.8	3.6	N/A	103.8
Intermittent Duty	82.3	64.7	40.0	26.5	18.8	16.5	13.2	N/A	N/A

Additional Specifications:

- Dielectric Strength: 1000 VRMS
- Recommended Heat Sink: Maximum watts dissipated by solenoid are based on an unrestricted flow of air at 20°C, with solenoid mounted to the equivalent of an aluminum plate measuring 4" square by 1/8" thick.
- Total Unit Weight: 6.73 oz. / 190.8 g
- Plunger Weight: 1.19 oz. / 33.7 g