

F5

F5

Characteristics	<ul style="list-style-type: none"> ■ small switch ■ long mechanical and electrical life ■ PCB mounting
Rating	250 VAC, 5 A
Dimensions (mm)	12.8 × 7 × 5
Actuator	<ul style="list-style-type: none"> ■ plunger ■ plain lever ■ simulated roller lever/cam follower
Approvals	UL, CSA



Preferred Range

Ordering Reference	Actuating Force (N) (ozf)		Sealing	Operating pos. (mm) (in)		Terminal	Circuit	Actuator	Contacts	Electrical rating
F5T8UL	1.4	5.00	IP40	8.75	0.34	PCB	CO	Plunger	Ag	Up to 250 VAC, 5 A
F5T8GPUL	1.4	5.00	IP40	8.75	0.34	PCB	CO	Plunger	Gold plate	Up to 250 VAC, 5 A
F5T8Y1UL	0.6	2.20	IP40	8.80	0.35	PCB	CO	Plain lever	Ag	Up to 250 VAC, 5 A
F5T8Y1GPUL	0.6	2.20	IP40	8.80	0.35	PCB	CO	Plain lever	Gold plate	Up to 250 VAC, 5 A
F5T8YCUL	0.7	2.50	IP40	10.90	0.43	PCB	CO	Simulated roller	Ag	Up to 250 VAC, 5 A
F5T8YCGPUL	0.7	2.50	IP40	10.90	0.43	PCB	CO	Simulated roller	Gold plate	Up to 250 VAC, 5 A

Specifications

Housing	Glass fibre reinforced nylon
Plunger	Nylon
Mechanism	Snap-action, single pole
Functions	Change-over, Normally open, Normally closed
Contacts	Fixed, Moving - Silver or Gold plate on silver
Terminals	PCB - Brass, gold flashed
Temperature range °C	-40°C to +85°C
Mechanical life	10 ⁷ cycles minimum (impact free actuation)
Protection	IP 40 (enclosure)
Mounting	PCB
Actuators	Plain lever; simulated roller (cam follower) lever

Circuit diagram

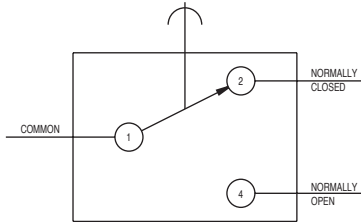

Dimensions

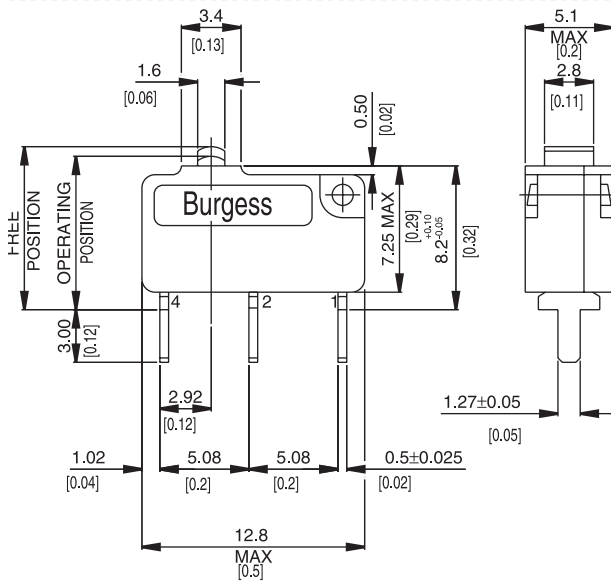

Recommended maximum electrical ratings

Voltage (max)	Load (A)	Approval
250 VAC	5 (0.75 pf)	UL 1054/CSA 22.2 No. 55 - 6,000 operations
125 VAC	5 (0.75 pf)	UL 1054/CSA 22.2 No. 55 - 6,000 operations
0 - 15 VDC	5	General rating - 50,000 operations
15 - 30 VDC	1	General rating - 50,000 operations

Operating Characteristics

Actuator	Reference	Actuating Force Maximum		Release Force Minimum		Free Position Maximum		Operating Position		Movement Differential Maximum		Over travel
		(N)	(ozf)	(N)	(ozf)	(mm)	(in)	(mm)	(in)	(mm)	(in)	
Plunger	F5T8	1.4	5.00	0.25	0.90	9.5	0.37	8.75 ± 0.3	0.34 ± 0.012	0.13	0.005	*
Y1-Lever	F5T8Y1	0.6	2.20	0.07	0.25	10.7	0.42	8.8 ± 1.1	0.35 ± 0.04	0.70	0.030	*
<p>Width of lever 3.0 mm/0.12 in</p>												
YC-Lever	F5T8YC	0.7	2.50	0.09	0.32	12.4	0.49	10.9 ± 0.85	0.43 ± 0.03	0.45	0.020	*
<p>Width of lever 3.0 mm/0.12 in</p>												

Operating characteristics are specified from the terminal shoulder.

* Plunger can be depressed flush with housing. The housing should not be used as an end stop.

Ordering Reference

Basic type	F5	Example: F5 T8 C2 Y1 GP UL										
Terminals	T8	PCB	1.27 × 0.5 × 3.0 long									
Circuit	C2	No symbol, change-over Normally closed										
	C4	Normally open										
Actuators	Y1	No symbol, without lever Plain lever 21.0 mm										
	YC	Cam follower lever 16.9 mm										
Contact Material	GP	No symbol, Ag Gold plate on Ag (GP)										
Approvals	UL	No symbol, without approval UL and CSA approval										
Special Features	/	<p>Burgess specialise in customer specific solutions. Additional product variants are available or can be provided. If your requirements cannot be satisfied from the options listed, please contact www.saia-burgess.com or your local SB outlet.</p>										