

Description

Legacy Power Relays

9A

SPST-NO, 30 A;

SPDT, 30 A (NO) / 20 A (NC)



9AS7D5

Description

The 9A series power relays offer robust performance in applications such as HVAC, motor controls, and alarm systems.

Feature	Benefit
Standard Class F insulation	Allows for maximum coil temperature of 155 °C (311 °F) which is ideal for high temperature applications
FLA/LRA and hp ratings	Capable of handling motor loads
Ballast load ratings	Suitable for lighting control applications
Small package size	Ideal for small spaces
Standard Quick Connect terminals	Simplifies and expedites installation

Rated Contact Current	Contact Configuration	Coil Voltage	Coil Resistance (Ω)	Standard Part Number
30 A	SPST-NO	12 Vac	25	9AS3A12
		24 Vac	100	9AS3A24
		120 Vac	2500	9AS3A120
		240 Vac	13490	9AS3A240
		5 Vdc	27	9AS3D5
		12 Vdc	155	9AS3D12
30 A (NO); 20 A (NC)	SPDT	24 Vac	100	9AS7A24
		120 Vac	2500	9AS7A120
		240 Vac	13490	9AS7A240
		5 Vdc	27	9AS7D5
		12 Vdc	155	9AS7D12
		24 Vdc	660	9AS7D24

Part Number Explanation

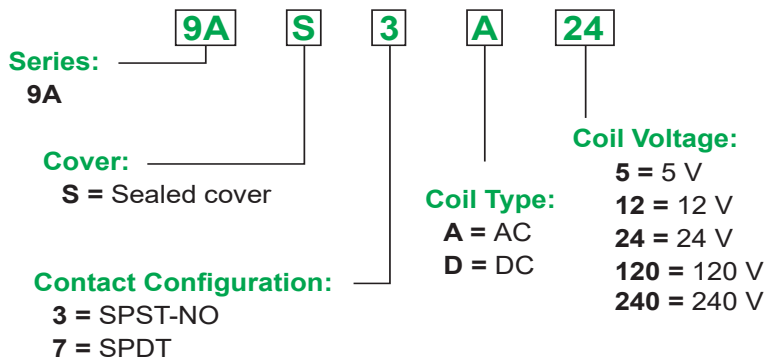

Legacy Power Relays

9A

SPST-NO, 30 A;

SPDT, 30 A (NO) / 20 A (NC)

Specifications (UL60947-4-1)

Part Number	9AS3	9AS7
Contact Characteristics		
Contact Configuration	SPST-NO	SPDT
Contact Material	Silver alloy	
Thermal (Carrying) Current	30 A	30 A (NO); 20 A (NC)
Maximum Switching Voltage	277 Vac / 28 Vdc	
Current Ratings at Voltage	<p>General purpose: AC1, 30 A, 240 Vac, 100,000 cycles, 40 °C (104 °F)</p> <p>Resistive: 30 A, 28 Vdc Resistive 50,000 cycles, 40 °C (104 °F); 24 A, 240 Vac Resistive 100,000 cycles, 60 °C (140 °F)</p> <p>Motor: 1 hp 125 Vac, 1,000 cycles, 40 °C (104 °F); 2 hp 250 Vac, 1,000 cycles, 40 °C (104 °F)</p> <p>LRA/FLA: AC-8a, 98/22 A 120 Vac, 30,000 cycles, 40 °C (104 °F)</p> <p>Ballast: AC-5a, 10 A, 277 Vac, 6,000 cycles, 40 °C (104 °F)</p> <p>Pilot Duty: 470 VA, 240 Vac 6,000 cycles, 40°C (104 °F)</p>	<p>General purpose: NO: AC1, 30 A, 240 Vac, 100,000 cycles, 40 °C (104 °F); NC: AC1, 20 A, 240 Vac, 100,000 cycles, 40 °C (104 °F);</p> <p>Resistive: NO: 30 A, 28 Vdc Resistive,50,000 cycles, 40 °C (104 °F); NC: 10 A, 28 Vdc Resistive,100,000 cycles, 40 °C (104 °F)</p> <p>Motor: NO: 1 hp 125 Vac, 1,000 cycles, 40 °C (104 °F); NO: 2 hp 250 Vac, 1,000 cycles, 40 °C (104 °F); NC: ¼ hp 125 Vac, 1,000 cycles, 40 °C (104 °F); NC: ½ hp 250 Vac, 1,000 cycles, 40 °C (104 °F)</p> <p>LRA/FLA: NO: AC-8a, LRA/FLA 98/22 A, 120 Vac, 30,000 cycles, 40 °C (104 °F); NO: AC-8a, LRA/FLA 80/30 A, 240 Vac, 30,000 cycles, 40 °C (104 °F); NC: AC-8a, LRA/FLA 30/12 A, 240 Vac, 30,000 cycles, 40 °C (104 °F); NC: AC-8a, LRA/FLA 33/10 A, 277 Vac, 30,000 cycles, 40 °C (104 °F)</p> <p>Ballast: NO: AC-5a, Ballast 10A, 277 Vac, 6,000 cycles, 40 °C (104 °F); NC: AC-5a, Ballast 3A, 277 Vac, 6,000 cycles, 40 °C (104 °F)</p> <p>Pilot Duty: NO: Pilot duty 470 VA, 240 Vac, 6,000 cycles, 40 °C (104 °F); NC: Pilot duty 275 VA, 240 Vac, 6,000 cycles, 40 °C (104 °F)</p>
Minimum Switching Requirement	1A at 12 Vac, 5 Vdc	

Part Number	9AS3	9AS7
Coil Characteristics		
Coil Voltage Range ¹	12–240 Vac, 50/60 Hz; 5–24 Vdc ¹	
Operating Range (% of Nominal)	85%–110% (AC); 80%–110% (DC)	
Average Consumption	2.6 VA (AC); 0.9 W (DC)	
Insulation System	Class F (155 °C / 311 °F)	
Drop-out Voltage Threshold	10% (DC) , 20% (AC)	

Note: Actual product performance may vary depending on application and environmental conditions.

¹ For available standard coil voltages, refer to the standard part number table on page 26.

Legacy Power Relays

9A
SPST-NO, 30 A;
SPDT, 30 A (NO) / 20 A (NC)

Part Number	9AS3	9AS7
General Characteristics		
Electrical Life at Rated Load	100,000 cycles, unless otherwise specified under "Current Ratings at Voltage"	
Mechanical Life at No Load (Unpowered)	10,000,000 operations	
Operate Time at Nominal Coil Voltage	20 ms	
Dielectric Strength	Between coil and contact: 2500 Vac; Between contacts: 1500 Vac	
Operating Temperature Range	-40 to 40 °C (40 to +104 °F)	
Storage Temperature Range	-40 to +85 °C (-40 to +185 °F)	
Vibration Resistance	+/- 0.75 mm 10–55 Hz	
Shock Resistance	10 g-n	
Weight (Average)	32 g (1.13 oz)	
Agency Certifications	UL	

Note: Actual product performance may vary depending on application and environmental conditions.

SPDT/SPST-NO dimensions — inches (millimeters)

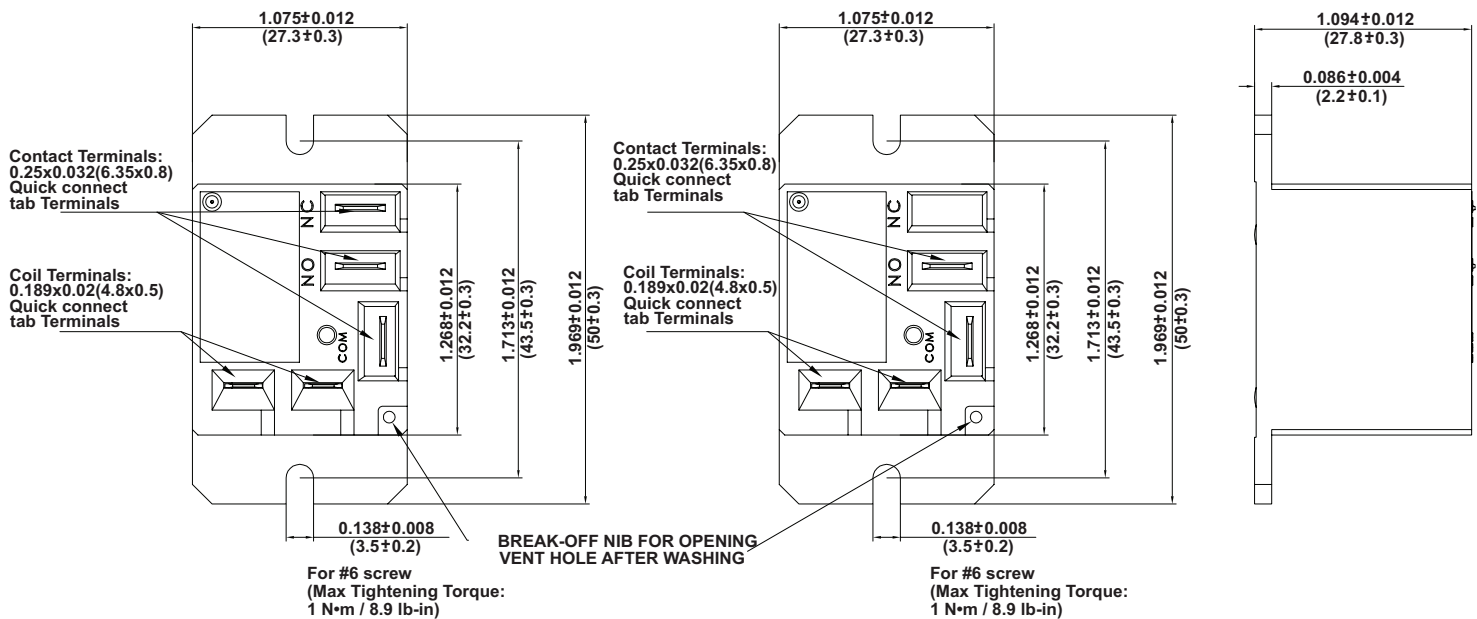

Wiring Diagrams

All diagrams are shown from top view

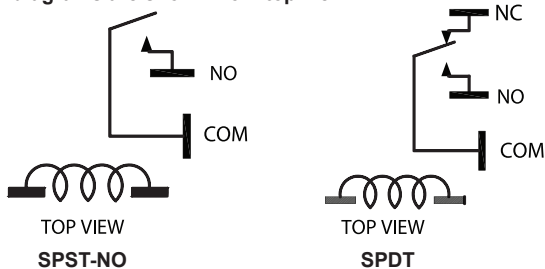

Legacy Power Relays

9A

DIN Rail Adapter, 16-9ADIN-1



16-9ADIN-1

Description

The 16-9ADIN-1 DIN rail adapter provides the mounting flexibility needed to mount the 9 A power relay in a panel board or control box.

Description	Function	For Use with Relays	Packaging Minimum	Standard Part Number
DIN Rail Adapter	Enables the 9A relay to be mounted directly to a DIN rail	9A series relays	10	16-9ADIN-1

Dimensions — inches (millimeters)

